



DETECTORS
INCORPORATED
safety • security • peace of mind

0212 944 57 00

info@detectorsturkiye.com

www.detectorsturkiye.com

Model D390 3IR + UV Flame Detector

INSTRUCTION MANUAL



Detectors Inc. Türkiye
Bahcesehir 1. Kısım Mah. Dalgıckusu Cad.
Defne 05 Ada 02 Villa
Basaksehir / Istanbul / Turkey



Tel : (0212) 944 57 00
Email : info@detectorsinctorkiye.com
Web : www.detectorsinctorkiye.com

Table of Contents

INTRODUCTION	3
Product description.....	3
Specifications.....	4
General.....	4
Electrical.....	4
Environmental.....	4
Mechanical.....	4
INSTALLATION.....	5
Detector Dimensions.....	5
Mounting the Detector.....	5
Positioning.....	5
Direct Mounting.....	5
Installation Tips.....	5
Detector Configuration.....	6
Detector Wiring.....	6-11
OPERATION AND STARTUP.....	12
Detector Performance and Response.....	12
Detector Operation.....	12
Detector Visual Status Indication.....	12
Normal Operation.....	12
ALARM Operation.....	12-13
Fault Operation.....	13
Detector Self-Test.....	14
Detector Optical Path Test.....	14
MAINTAINANCE.....	14
Inspection and Cleaning.....	14
Periodic Testing.....	14
TROUBLESHOOTING.....	15
EVENT LOG.....	15
ACCESSORIES.....	15
PRODUCT SUPPORT.....	15
Technical Support and Customer Support.....	15
WARRANTY.....	16
APPENDIX “A”	
ORDERING INFORMATION.....	17
APPENDIX “B”	18



1.0 Introduction

1.1 Product Description

The Multi-Spectrum **D390** is a stand-alone 3IR flame detector designed specifically for installation in Semiconductor clean rooms and wet benches for fast detection of Hydrocarbon and Non-Hydrocarbon based fires. The Model D390 senses the IR radiation in 3 discrete bands of Infrared in the range of 2-5 microns.

The Model **D390** sensors and electronic circuit boards are enclosed in a sealed water-tight Polypropylene enclosure rated IP67 making it an ideal detector for installing in harsh chemical laden environment. The detector can be used as a stand-alone device or can be interfaced with any approved fire alarm panel. The detector will respond to one square-foot n-Heptane fire within 3-5 seconds from of 30 feet.



1.2 Specifications

1.2.1 General

Field-of-View:	90° Horizontal & Vertical
Spectral Sensitivity:	IR: 2-5 microns (3 discrete bands)
Response Time:	3-5 Seconds
Detection Range:	1' x 1' n-Heptane fire: 30 feet 32" Hydrogen plume (3/8" orifice): 20 feet

1.2.2 Electrical

Operating Voltage:	24 VDC nominal (18-31), Regulated
Power Consumption:	Standby: 60 mA @ 24 VDC Alarm: 90 mA @ 24 VDC
Relays Outputs:	Alarm & Auxiliary Relays: SPDT—contacts rated 2A @ 24 VDC De-Energized with N.O. contacts (power applied) Fault relay: SPST – contact rated 2A @ 24 VDC Energized with Closed contact (power applied)
Analog Output:	0-20 mA Stepped - Source
Communication:	RS485 ModBus
Visual Indications:	Green LED - Normal Red LED - Alarm Amber LED - Fault
Wiring	Integral multi-conductor cable harness with Teflon Jacket 20 AWG 15-conductor cable, 20' long

1.2.3 Environmental

Humidity Range:	5 to 95% relative humidity, non-Condensing
Temperature Range:	-40 to +185°F (-40 to +85 °C)
Enclosure Type:	NEMA 4, IP67

1.2.4 Mechanical

Enclosure Material:	Polypropylene, sealed
Weight:	1.5 lbs. (0.7 kg)

2.0 Installation

2.1 Detector Dimensions

The D390 detector has (4) 6mm holes in the rear mounting flange (Figure 1) that can be used to mount the detector directly on a flat surface. The detector can also be mounted using an optional Polypropylene swivel mounting bracket (Figure 2) that allows the detector adjustment in vertical axis.

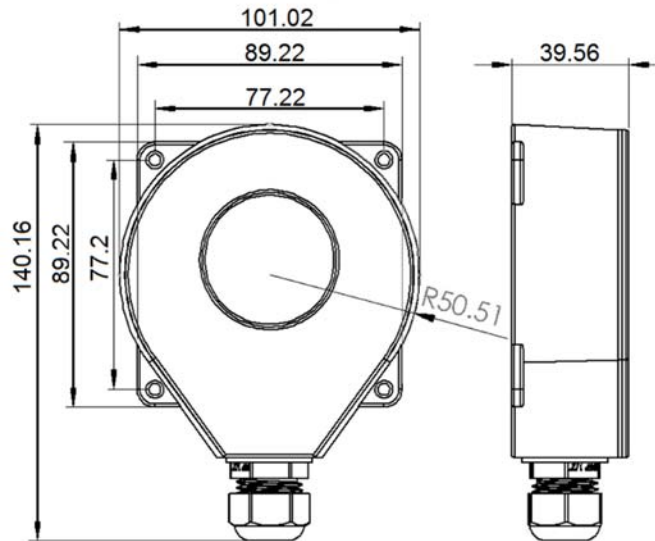

Figure 1 – Detector Dimensions

2.2 Mounting the Detector

2.2.1 Positioning - The detector should be installed such that the center of the detector's field-of-view is aimed directly at the center of the area to be protected (hazard area). Detectors should be installed above the hazard area pointing downward with no obstruction of the Field-of-View.

2.2.2 Direct Mounting. - The detector may also be mounted directly to a flat surface using the (4) mounting hole on the rear mounting flange and secure it firmly with (4) stainless steel screws.

2.2.3 Installation Tips: - When installing the detectors, be aware of the following conditions:

- If detectors are installed in a compartment containing chemical baths or heaters, care should be taken not to exceed the detector's maximum operating temperature.
- Field-of-View of detectors should not be blocked by any objects for optimum performance.
- Detectors should be installed such that there are no high intensity lights in the view of detectors. High intensity lights may diminish detector sensitivity.
- Detectors should be installed so that they are easily accessible for maintenance.

2.3 Detector Configuration

2.3.1 Unless specified otherwise, the **D390** detectors are shipped factory configured as described below, with power applied:

Fire Alarm Relay:	SPDT, Normally De-Energized, N.O., Non-Latching
Auxiliary Relay:	SPDT, Normally De-Energized, N.O., Non-Latching
Fault Relay:	SPST, Normally Energized, N.C., Non-Latching
4-20 mA	Stepped Analog, Sourcing
Communication	ModBus RTU Protocol

2.3.2 All relays with standard factory configuration are “Non-Latching”. If “Latching” mode is required, it must be specified when ordering. Please refer to Appendix “A” for other configuration options.

2.3.3 Maximum loop resistance for the analog output is 800 Ohms

2.3.4 The **D390** Detector is also equipped with a standard RS485 ModBus communication protocol for interfacing with devices or controllers using the Modbus standard. The RS485 communication protocol is also useful in communicating with detector for viewing or downloading the Event Logs and FireGraphs using a laptop and the LabVIEW programming software.

2.4 Detector Wiring

2.4.1 The **D390** Detector is supplied with an integral multi-conductor shielded cable with Individual conductors color-coded for easy identification (Table 1).

2.4.2 Detector should be wired in according with the National Electrical Code (NFPA 70) Division 2 hazardous (Classified) location wiring procedure in the United States or according to the local codes in other countries, observing the requirements for Electrical Safety.

2.4.3 Terminate each color-coded wire to an appropriate terminal in the Fire Alarm Panel, PLC, or Control System. Figures 3-6 shows various wiring configurations for the detector.

Table 1 – D390 Detector Wiring Identification

Wire Number	Wire Color	Description
3	Red	24 VDC (+)
1	Black	24 VDC (Return)
8	Red/Black	Alarm Relay Contact A (COM)
13	Red/White	Alarm Relay Contact B (N.O.)
4	Green	Fault Relay Contact A (COM)
9	Green/Black	Fault Relay Contact B (N.O.)
5	Orange	Auxiliary Relay Contact A (COM)
10	Orange/Black	Auxiliary Relay Contact B (N.O.)
2	White	ModBus RTU (+)
7	White/Black	ModBus RTU (-)
6	Blue	4-20 mA (+) - Source
11	Blue/Black	Test
12	Black/White	(Not Used)
14	Green/White	Alarm Relay Contact A Loop Through (*)
15	Blue/White	Alarm Relay Contact B Loop Through (*)
Cable Shield		

(*): Loop through wires can be used for adding an End-of-Line resistor to supervise the Alarm relay contacts.



Basic Wiring Schematics

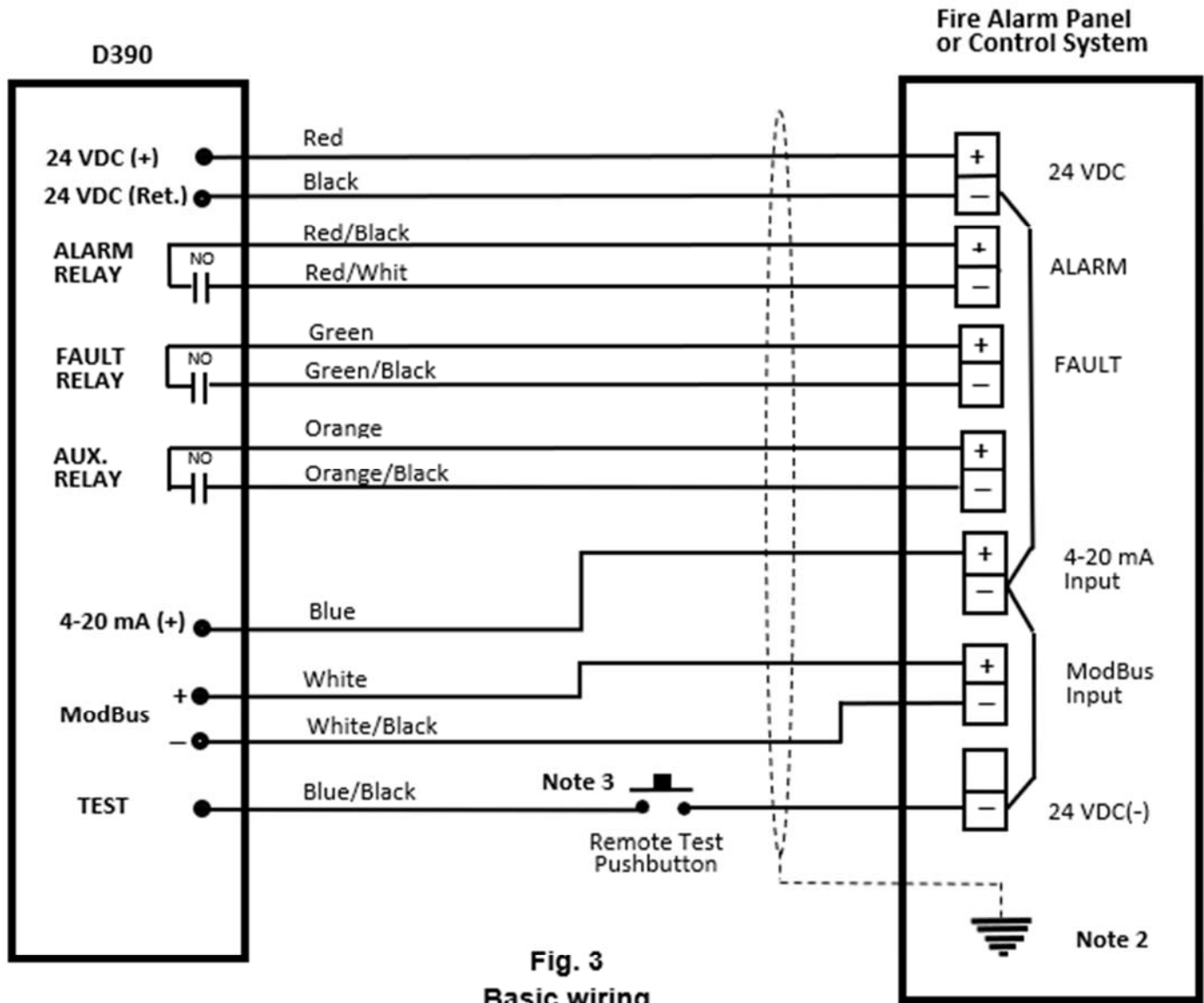

NOTES:

1. Fire Alarm and Auxiliary relays are normally De-Energized with Open Contacts. Fault relay contact is Normally open with no power. Fault relay will Energize and contact closes when power is applied.
2. Cable shield must be connected to "Earth Ground" at one location only preferably at the panel location.
3. Connecting the terminal labeled "Test" to 24 VDC (Return) will initiate detector's automatic self-test feature. Detector will cycle through its self-test checking the sensors and activating both Fire Alarm & Aux. relays and verifying through-the-lens test. A momentary "Test" pushbutton switch may be installed in the Control Center for testing detector. **(CAUTION: Activation of the Remote Test pushbutton will energize the Fire Alarm & Auxiliary relays which may activate the suppression system. The suppression system should be bypassed or isolated before testing the detector).**

Typical Detector Wiring

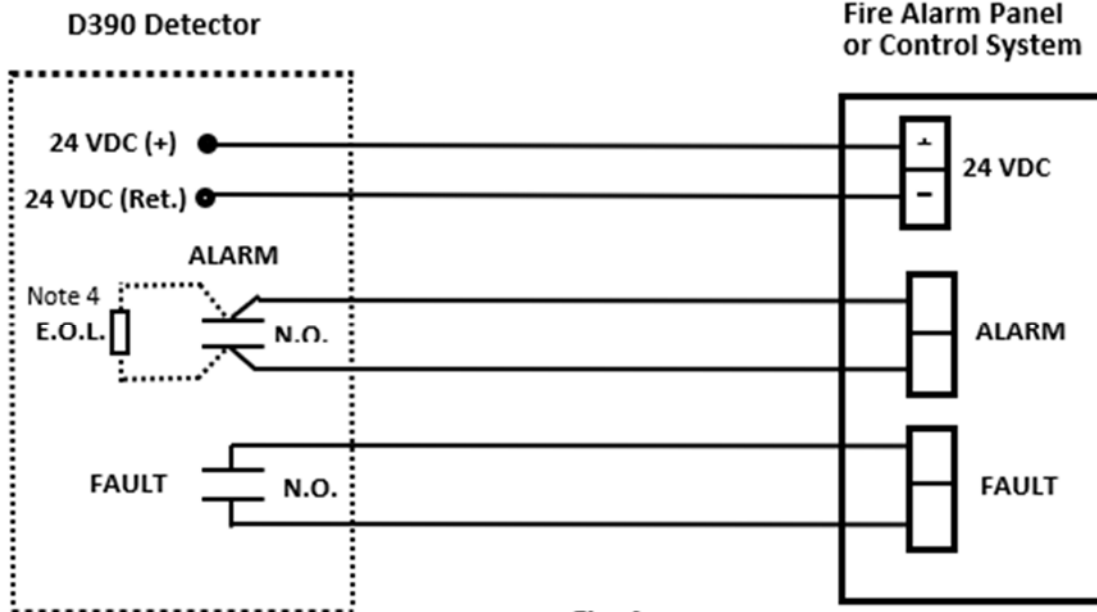

Fig. 4
4-Wire Alarm & Fault
Class B Wiring

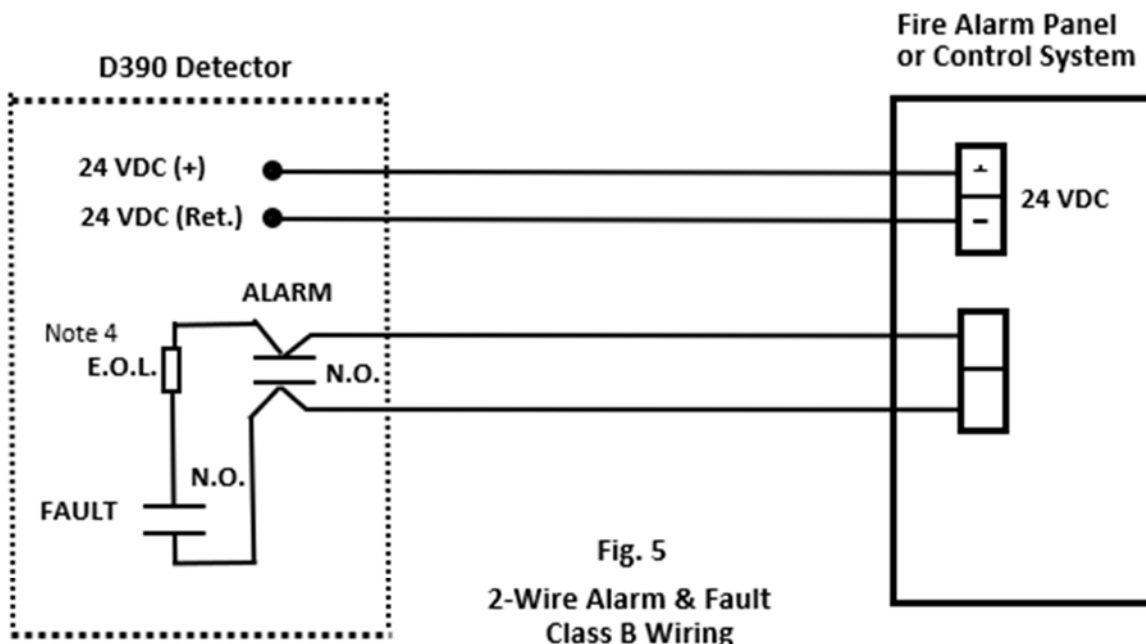
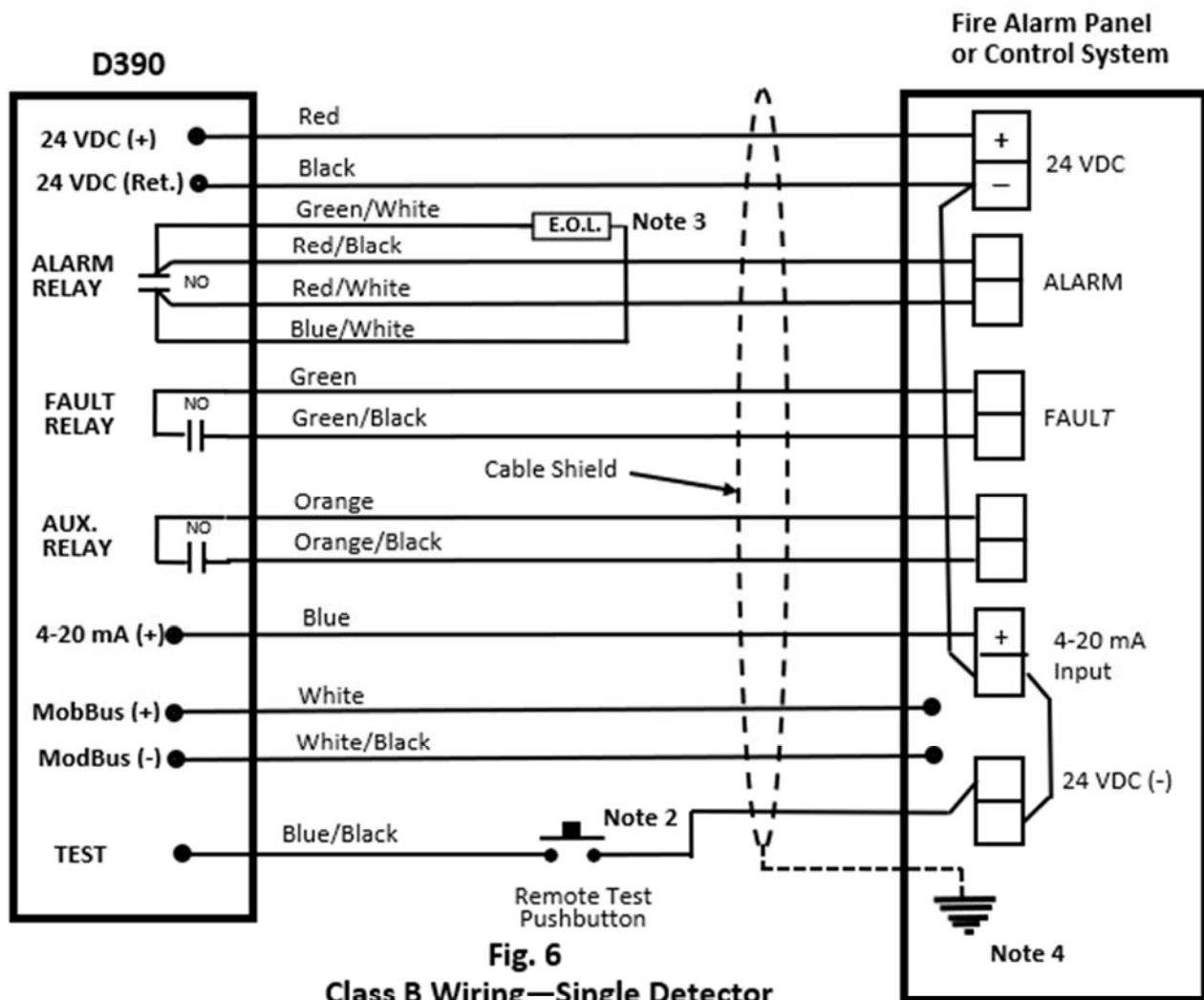

Fig. 5
2-Wire Alarm & Fault
Class B Wiring

Notes:

1. Relay contacts shown with no power applied.
2. During normal operation and with no Alarm, Alarm & Aux. relays are De-Energized with OPEN contacts.
3. Fault relay is Energized with CLOSED contacts during normal operation with no Fault.
4. The End-of-Line (EOL) device by Fire Alarm Panel manufacturer.

DETECTOR D390 WIRING SCHEMATIC



NOTES:

1. Relay contacts shown above are with no power applied to detector. With power applied, Alarm & Aux. relays are normally De-Energized with Open contacts. Fault relay will Energize with Closed contacts. When Fault occurs, Fault relay will De-Energize.
2. Pressing the remote Test pushbutton will initiate detector's automatic self-test feature. Detector will cycle through its self-test checking the sensors and activating the Fire Alarm & Aux. relays and verifying through-the-lens test. The Test pushbutton should be installed at the Control Panel or Fire Alarm Panel. (CAUTION: Activation of the Remote Test pushbutton will energize the Fire Alarm & Aux. relay which may activate the suppression system. The suppression system should be bypassed or isolated before testing the detector).
3. In Hazardous areas, the End-of Line (E.O.L.) supervisory Resistor must be located either in an explosion-proof junction box or in a safe area. E.O.L. device by others.
4. Cable shield must be connected to "Earth Ground" at one location only preferably at the panel.

DETECTOR D390 WIRING SCHEMATIC

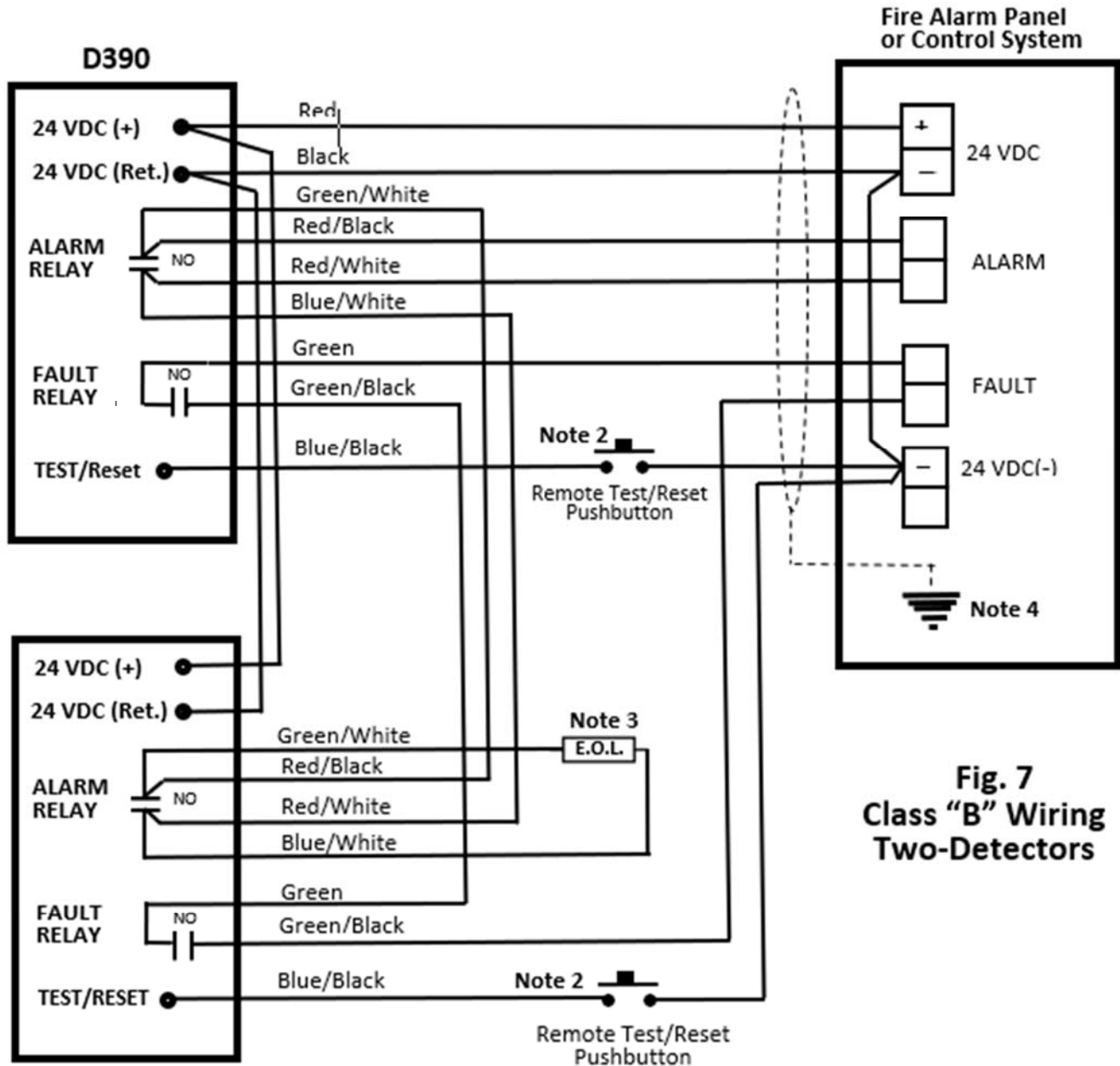

Fig. 7
Class "B" Wiring
Two-Detectors

NOTES:

1. Relay contacts shown above are with no power applied to detector. When power is applied, Alarm relay is normally De-Energized with N.O. contacts. Fault relay is Energized with N.C. contacts. When Fault occurs, Fault relay will De-Energize.
2. Connecting the remote Test pushbutton will initiate detector's automatic self-test feature. Detector will cycle through its self-test checking the sensors and activating the relays and verifying through-the-lens test. The Test push-button should be installed at the Control Panel or Fire Alarm Panel. (CAUTION: Activation of the Remote Test/Reset pushbutton will energize the Fire Alarm relay which may activate the suppression system. The suppression system should be bypassed or isolated before testing the detector).
3. In Hazardous areas, the End-of Line (E.O.L.) Supervisory Resistor must be located either in an explosion-proof junction box or in a safe area. E.O.L. device supplied by the Fire Alarm Panel manufacturer.
4. Cable shield must be connected to "Earth Ground" at one location only preferably at the panel.

3.0 Operation & Startup

3.1 Detector Performance & Response

The **D390** is a Multi-Spectrum Infrared fire and flame detector designed for detection of Hydrocarbon and Non-Hydrocarbon fires. The detector includes 3 separate Quantum IR sensors tuned precisely to 3 separate bands of IR radiation in the electromagnetic spectrum for responding to various types of fires. The detector electronics module assembly is encased in a sealed Polypropylene enclosure and is offered with an integral multi-conductor cable with Teflon jacket suitable for using in harsh and chemical laden environment. Detector's response to a flame is normally 3-5 seconds and the response time will depend on the size of the flame and the distance from the flame.

3.2 Detector Operation

Once powered up, the **D390** detector will go through its self-diagnostics process and will be ready for operation after 10 seconds. During the self-diagnostic process, the Green, Amber, and Red LEDs will turn on sequentially indicating this process. During the self-diagnostics, the Microprocessor will check the status of IR sensors, relays, various devices, and the self-test feature. Once the Microprocessor determines that all devices and functions have been tested and found to be within the specifications, it will then terminate the self-test diagnostics and will return the detector to normal operation. During the normal operation, the Green LED will be turn "ON" for 1 second and "OFF" for 1 second indicating that the detector is now ready to detect fires.

3.3 Detector Visual Status Indications

The D390 detector has (3) bright LEDs for indicating the status of the detector:

Green LED	Normal operation
RED LED	Alarm condition
Amber LED	Fault condition

3.3.1 Normal Operation:

During the normal operation, with no Alarm and no Fault existing, the detector will turn the Green LED "ON" for 1 second and "OFF" for 1 second indicating normal status. Unless otherwise specified the detector will be shipped with the following standard factory relay output configuration:

Alarm relay	Normally De-Energized
Auxiliary Relay	Normally De-Energized
Fault relay	Normally Energized
Analog output	4.0 +/- 0.2 mA

3.3.2 Alarm Condition:

When the **D390** detector is exposed to fires and declares Alarm, the following conditions will occur (with standard factory configurations):

Red Alarm LED	Will turn “ON” steady
Green LED	Will continue flashing “ON” and “OFF”
Alarm relay	Will be activated
Fault relay	Remains Energized
Analog output	20.0 +/- 0.2 mA
ModBus output	“Alarm” Command

Please note that the Red Alarm LED will remain “ON” and the Alarm relay will remain Energized as long the fire is present. Once the fire has been extinguished the detector status will be as follows:

- Non-Latching Alarm Relay mode:** The detector will automatically reset itself by De-Energizing the Alarm Relay, turning off the Red LED and removing the Alarm command from ModBus output
- Latching Alarm Relay mode:** The detector status will remain unchanged with Alarm relay still Energized and the Red Alarm LED remaining “ON” until the detector is reset by removing the 24 VDC power from detector momentarily.

3.3.3 Fault Condition:

During a Fault condition, the following conditions will occur ((with standard factory configurations):

Amber LED	Will turn “ON” steady
Green LED	Will continue flashing “ON” and “OFF”
Fault relay	Will be De-Energized (deactivated)
Analog output	2.0 +/-0.2 mA Dirty window 0.3 – 0.9 mA Other Faults
ModBus output	“Fault” Command

- Non-Latching Fault Relay mode (Factory default):** When the Fault has been cleared, the detector will automatically reset itself by turning off the Amber LED and Energizing the Fault relay.
- Latching Fault Relay mode:** When the Fault clears, the detector status will remain unchanged with Fault relay still De-Energized and the Amber Fault LED remaining “ON” until the detector is reset by removing the 24 VDC power from detector momentarily.
- A Fault may occur if one or more of the following conditions exist (with standard factory configurations):
 - Faulty Sensor (IR)
 - Faulty Microprocessor
 - Faulty Relay
 - Damaged component
 - Low input power (less than 18 VDC)
 - High input power (higher than 32 VDC)
 - High temperature
 - Dirty viewing window

3.3.4 Detector Self-Test:

The **D390** detector is programmed to perform an automatic diagnostic self-test periodically (factory default is every 5 minutes). During the automatic Self-Test, the detector will turn on both Amber LEDs flashing for 2-3 seconds. Following the automatic Self-Test, the detector will return to Normal Operation if no Fault was detected.

3.3.5 Detector Optical Path Test:

The detector also monitors the cleanliness of its viewing window and blockage of its viewing window every second using the **OptiRadar** feature. If the contamination of the window exceeds the preset threshold, the detector will declare a Fault. The detector also monitors the blockage of the window by external objects. If an object is placed on the surface of the window, the detector will turn on its Amber light flashing for 60 seconds; and if the blockage is not removed after 60 seconds, the detector will declare a Fault by changing the flashing Amber light to steady on.

4.0 Maintenance

4.1 Inspection and Cleaning

Once the detector has been installed and powered up, it should provide maintenance free performance for years. The following is a simple guideline for keeping the detector functioning properly and trouble free:

4.1.1 The **D390** detector required no field calibration or adjustment.

4.1.2 The detector is encased in a sealed Polypropylene enclosure requiring very little maintenance. However; in harsh chemical-laden environment, dusty and oily places contaminant tend to accumulate on the front viewing window thus reducing the detector sensitivity. It is therefore recommended to check the detector and clean the front surface as needed with soft cotton cloth and IPA (Isopropyl Alcohol). Prior to cleaning the front viewing window, it is recommended to disconnect power to detector.

4.1.3 The detector is fitted with a Teflon cable compression fitting and tightened to proper torque for maintaining the integrity of leak-proof enclosure. Under no circumstance the Teflon compression fitting should be adjusted. If the fitting becomes loose, please either return the detector to factory for the fitting to be re-torqued or call the factory for exact torque setting.

4.2 Periodic Testing

The detector should also be functionally tested end-to-end annually or as required by local codes or authorities having jurisdiction. Prior to testing the system, all detector outputs to Fire Alarm Panel or extinguishing systems should be disabled or disconnected. The functional test should be performed by qualified personnel being familiar with the system.

5.0 Troubleshooting (to be added later)

6.0 Event Log & FireGraph (to be added later)

7.0 Accessories (to be added later)

8.0 Product Support

8.1 Technical Support and Customer Support

For Technical and Customer Support and questions concerning the detectors or applications, please contact:

Detectors Inc. Türkiye
Bahcesehir 1. Kısım Mah. Dalgıckusu Cad.
Defne 05 Ada 02 Villa
Basaksehir / Istanbul / Turkey



Tel : (0212) 944 57 00
Email : info@detectorsincturkiye.com
Web : www.detectorsincturkiye.com

9.0 Warranty

Detectors Incorporated warrants the products manufactured and supplied by Detectors Incorporated against defects in materials and workmanship under normal use and service for a period of five (5) years from the date of shipment. Detectors Incorporated at its sole discretion will repair or replace at no charge any products found to be defective during the warranty period. The defective product must be shipped transportation paid to Detectors Incorporated or Distributor/Representative where the products was purchased. This express limited warranty is extended by Detectors Incorporated to the original purchaser only and is not assignable or transferable to any other party.

This warranty does not cover the following:

1. Damage incurred in transit.
2. Defects or damage from misuse, accident, “Act of God”, or neglect.
3. Defects or damage from improper installation, lack of maintenance, improper testing and operation.
4. Defects or damage caused by alterations, unauthorized dis-assemblies, repairs or modifications.
5. Damages caused by applying high voltage, electrical power surge or faulty power supplies.
6. Transportation charges to and from repair facility.
7. Illegal or unauthorized alterations of the firmware/software in the product.

This is the complete warranty for the products manufactured by Detectors Incorporated. Except for the warranty expressed above, Detectors Incorporated disclaims all other warranties express or implied with regards to its products sold. Detectors Incorporated sole liability under this warranty is limited only to repair or replacement of the products and shall not include any liability for consequential or other damages arising from the use of the product.

APPENDIX “A”

D390 DETECTOR ORDERING INFORMATION

	<u>D390</u> -	<u>a</u>	<u>b</u>	<u>c</u> -	<u>d</u>	<u>e</u>
Detector Model _____	↑					
D390: 3IR Detector						
Output Options _____		↑				
1 - Relays, 4-20mA, Modbus (Factory Default)						
Fire & Aux. Relay Configuration _____			↑			
1 - Normally De-Energized, Non-Latching (Factory Default)						
2 - Normally De-Energized, Latching						
3 - Normally Energized, Non-Latching						
4 - Normally Energized, Latching						
Fault Relay Configuration _____				↑		
1 - Normally Energized, Non-Latching (Factory Default)						
2 - Normally Energized, Latching						
Enclosure / O-Ring _____					↑	
P - Polypropylene with Viton O-Ring (Factory Default)						
K - Polypropylene with Kalrez O-Ring						
Cable Length _____						↑
1 - 20 Feet Cable (Factory Default)						
2 - 25 Feet Cable						
3 - 30 Feet Cable						
4 - 35 Feet Cable						
5 - 40 Feet Cable						
6 - 50 Feet Cable						

Example: **D390-111-P1**
Detector with Alarm & Aux. Relays Normally De-Energized Non-Latching. Fault Relay Normally Energized Non-Latching. With Viton O-Ring and 20-ft. Cable Length.

APPENDIX “B”

Detectors Inc. Türkiye
Bahcesehir 1. Kısım Mah. Dalgickusu Cad.
Defne 05 Ada 02 Villa
Basaksehir / Istanbul / Turkey



Tel : (0212) 944 57 00
Email : info@detectorsinoturkiye.com
Web : www.detectorsinoturkiye.com