



**DETECTORS**  
**INCORPORATED**  
*safety • security • peace of mind*

0212 944 57 00

info@detectorsturkiye.com

www.detectorsturkiye.com

## Model D381 3IR + UV Aluminum Flame Detector

### INSTRUCTION MANUAL



Detectors Inc. Türkiye  
Bahcesehir 1. Kısım Mah. Dalgıcıkusu Cad.  
Defne 05 Ada 02 Villa  
Basaksehir / Istanbul / Turkey



Tel : (0212) 944 57 00  
Email : info@detectorsinturkiye.com  
Web : www.detectorsinturkiye.com

## Table of Contents

<b>INTRODUCTION</b> .....	3	<b>TROUBLESHOOTING</b> .....	14
Product Description.....	3	<b>EVENT LOGS AND FireGraphs</b> .....	14
Specifications.....	4	<b>ACCESSORIES</b> .....	14
General.....	4	<b>PRODUCT SUPPORT</b> .....	14
Electrical.....	4	Technical Support and Customer Support.....	14
Environmental.....	4	<b>WARRANTY</b> .....	15
Mechanical.....	4	<b>APPENDIX “A”</b>	
<b>INSTALLATION</b> .....	5	Ordering Information.....	16
Detector Dimensions.....	5	<b>APPENDIX “B”</b> .....	17
Mounting the Detector.....	5		
Positioning.....	5		
Using Swivel Mounting Bracket.....	5		
Direct Mounting.....	5		
Installation Tips.....	5,6		
Detector Configuration.....	6		
Detector Wiring.....	6-8		
<b>DETECTOR SENSOR, LED INDICATIONS AND CONDUIT ENTRY LOCATION</b> .....	9		
<b>OPERATION AND STARTUP</b> .....	10		
Detector Performance and Response.....	10		
Detector Operation.....	10		
Detector Visual Indicators.....	10		
Normal Operation.....	10		
Alarm Condition.....	11		
Fault Condition.....	11,12		
Detector Self-Test.....	12		
Detector Optical Path Test.....	12		
<b>MAINTAINANCE</b> .....	12		
Inspection and Cleaning.....	12		
Detector Testing Procedures.....	12		
Periodic Testing.....	12		
Manual Test.....	13		
<b>D383 DETECTOR RESPONSE CHARACTERISTICS</b> .....	13		
Performance Testing.....	13		
Immunity to False Alarms.....	13,14		



## 1.0 Introduction

### 1.1 Product Description

The Detectors Inc. model **D381** is a new generation of general-purpose and medium range Multi-Spectrum 3IR + UV flame detector designed for detection of fires in multitude of indoor and outdoor applications. The Model **D381** senses the Ultraviolet radiation in UV spectrum and Infrared radiation in 3 discrete bands of IR in the range of 2-5 microns. The detector will respond to Hydrocarbon and non-Hydrocarbon based fires within 3 seconds.

The Model **D381** is a stand-alone flame detector in watertight NEMA 4 (IP67) and explosion-proof aluminum enclosure designed for Class I, Division 2 (Zone 2) installations. The detector offers multiple outputs including two fire alarm relays, 4-20 mA analog and RS485 ModBus RTU.

The detector can be used as a stand-alone device or can be interfaced with any approved fire alarm panel, control system, or PLC. The **D381** detector features an Automatic Self-Test for continuously monitoring its sensors and electronics. Additionally, the detector is equipped with **OptiRadar** feature that continuously checks the detector's optical path integrity and the window blockage by external objects. This feature will initiate a Fault signal if any object is blocking the viewing window within 1" of detector.



## 1.2 Specifications

### 1.2.1 General

Field-of-View:	90° Horizontal & Vertical
Spectral Sensitivity:	UV: 180-260 nanometers IR: 2-5 microns (3 discrete bands)
Sensitivity Range:	Low & High
Response Time:	Alarm: 3-5 Seconds
Detection Range:	1' x 1' n-Heptane fire: 80 feet

### 1.2.2 Electrical

Operating Voltage:	24 VDC nominal (18-31), Regulated
Power Consumption:	Standby: 60 mA @ 24 VDC Alarm: 90 mA @ 24 VDC
Relays Outputs:	Alarm & Auxiliary Relays: SPDT—contacts rated 2A @ 24 VDC De-Energized with N.O. contacts (power applied) Auxiliary relay settings: 0.3, 3, 10, 20 seconds <b>Factory Default for Aux. relay: 3 seconds</b>  Fault relay: SPST – contact rated 2A @ 24 VDC Energized with N.C. contact (power applied)
Analog Output:	0-20 mA Stepped - Source
Communication:	RS485 ModBus
Visual Indications:	<b>Green LED</b> – Normal Operation <b>Red LED</b> - Alarm <b>Amber LED</b> - Fault
Wiring	Integral 15-conductor pre-wired cable harness 20 AWG, 10' long

### 1.2.3 Environmental

Humidity Range:	5 to 95% relative humidity, non-Cond.
Temperature Range:	-40 to +185°F (-40 to +85°C)
Enclosure Type:	NEMA 4, IP67

### 1.2.4 Mechanical

Enclosure Material:	Aluminum, powder coated
Weight:	2 lbs. (0.9 kg)
Conduit Entry	(1) M25 – M25 X 3/4" adapter available
Mounting:	Swivel bracket—Optional

## 2.0 Installation

### 2.1 Detector Dimensions

The **D381** detector is supplied with powder coated Aluminum enclosure. The enclosure has (4) 7mm holes in the rear mounting flange (Figure 1) that can be used to mount the detector directly on a flat surface or onto the optional swivel mounting bracket that allows the detector adjustment in vertical and horizontal axis.

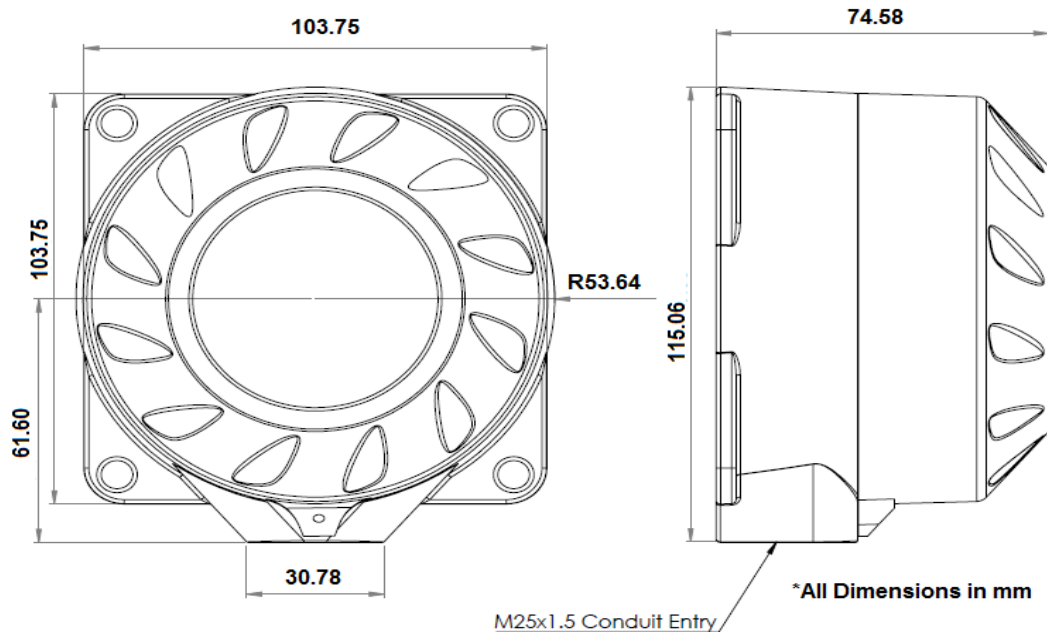

Figure 1 – Detector Dimensions

### 2.2 Mounting the Detector

- 2.2.1 Positioning** - The detector should be installed such that the center of the detector's field-of-view is aimed directly at the center of the area to be protected (hazard area). Detectors should be installed with no obstruction of the Field-of-View.
- 2.2.2 Using Swivel Mounting Bracket** – This method will allow the detector to be adjusted in vertical and horizontal axis for optimum orientation. First, secure the Swivel Mount to the surface to be mounted. Next attach the detector onto the swivel mounting bracket using bolts supplied.
- 2.2.3 Direct Mounting.** - The detector may also be mounted directly to a flat surface using the (4) 7 mm mounting holes on the rear mounting flange and secure it firmly with (4) steel screws.
- 2.2.4 Installation Tips:** - When installing the detectors, be aware of the following conditions:
- Field-of-View of detectors should not be blocked by any objects for optimum performance.
  - The detector should be installed such that the center of the detector is aimed at the center of the area to be protected (hazard area). Detectors should be installed above the hazard

area pointing downward at an angle between 35-55 degrees from horizontal with no obstruction of the Field-of-View. Detector height generally should be approximately 1½ to 2½ times the height of tallest object in the hazard area. The height may vary depending on the application, indoor/outdoor installation and size of the hazard area. Detector should be easily accessible for maintenance.

- c) For indoor applications, the detectors should be installed so that there are no high intensity lights in the view of detectors. High intensity lights may diminish detector sensitivity.
- d) Detectors should be installed so that they are easily accessible for maintenance.

## 2.3 Detector Configuration

2.3.1 Unless specified otherwise, the **D381** detectors are shipped factory configured as described

below: Fire Alarm Relay:	<b>SPST, Normally De-Energized, N.O., Non-Latching</b>
Warning Relay	<b>SPST, Normally De-Energized, N.O., Non-Latching</b>
Latching Fault Relay:	<b>SPST, Normally Energized, N.C., Non-Latching</b>
4-20 mA Communication	<b>Stepped Analog, Sourcing ModBus RTU Protocol</b>

2.3.2 All relays with standard factory configuration are “Non-Latching”. If “Latching” mode is required, it must be specified when ordering. Please refer to Appendix “A” for other configuration options.

2.3.3 Maximum loop resistance for the analog output is 800 Ohms

2.3.4 The **D381** Detector is also equipped with a standard RS485 ModBus communication protocol for interfacing with devices or controllers using the Modbus standard. The RS485 communication protocol is also useful in communicating with detector for viewing or downloading Event Logs and FireGraphs using a laptop and the LabVIEW programming software.

## 2.4 Detector Wiring

2.4.1 The **D381** Detector is supplied with an integral multi-conductor shielded cable with Individual conductors color-coded for easy identification (Table 1).

2.4.1 Detector should be wired in accordance with the National Electrical Code (NFPA 70) Division 2 hazardous (Classified) location wiring procedure in the United States or according to the local codes in other countries, observing the requirements for Electrical Safety.

2.4.2 Terminate each color-coded wire to an appropriate terminal in the Fire Alarm Panel, PLC, or Control System. Figure 3 shows the basic wiring configurations for the detector

**Table 1 - D381 Detector Wiring Identification**

Wire Number	Wire Color	Description
3	Red	24 VDC (+)
1	Black	24 VDC (Return)
8	Red/Black	Alarm Relay Contact A (COM)
13	Red/White	Alarm Relay Contact B (N.O.)
4	Green	Fault Relay Contact A (COM)
9	Green/Black	Fault Relay Contact B (N.O.)
5	Orange	Auxiliary Relay Contact A (COM)
10	Orange/Black	Auxiliary Relay Contact B (N.O.)
2	White	ModBus RTU (+)
7	White/Black	ModBus RTU (-)
6	Blue	4-20 mA (+)
11	Blue/Black	Test
12	Black/White	Not Used
14	Green/White	Not Used
15	Blue/White	Not Used
Cable Shield		To be terminated at chassis ground of PLC or Fire Alarm Panel

## 2.5 Basic Wiring Schematics

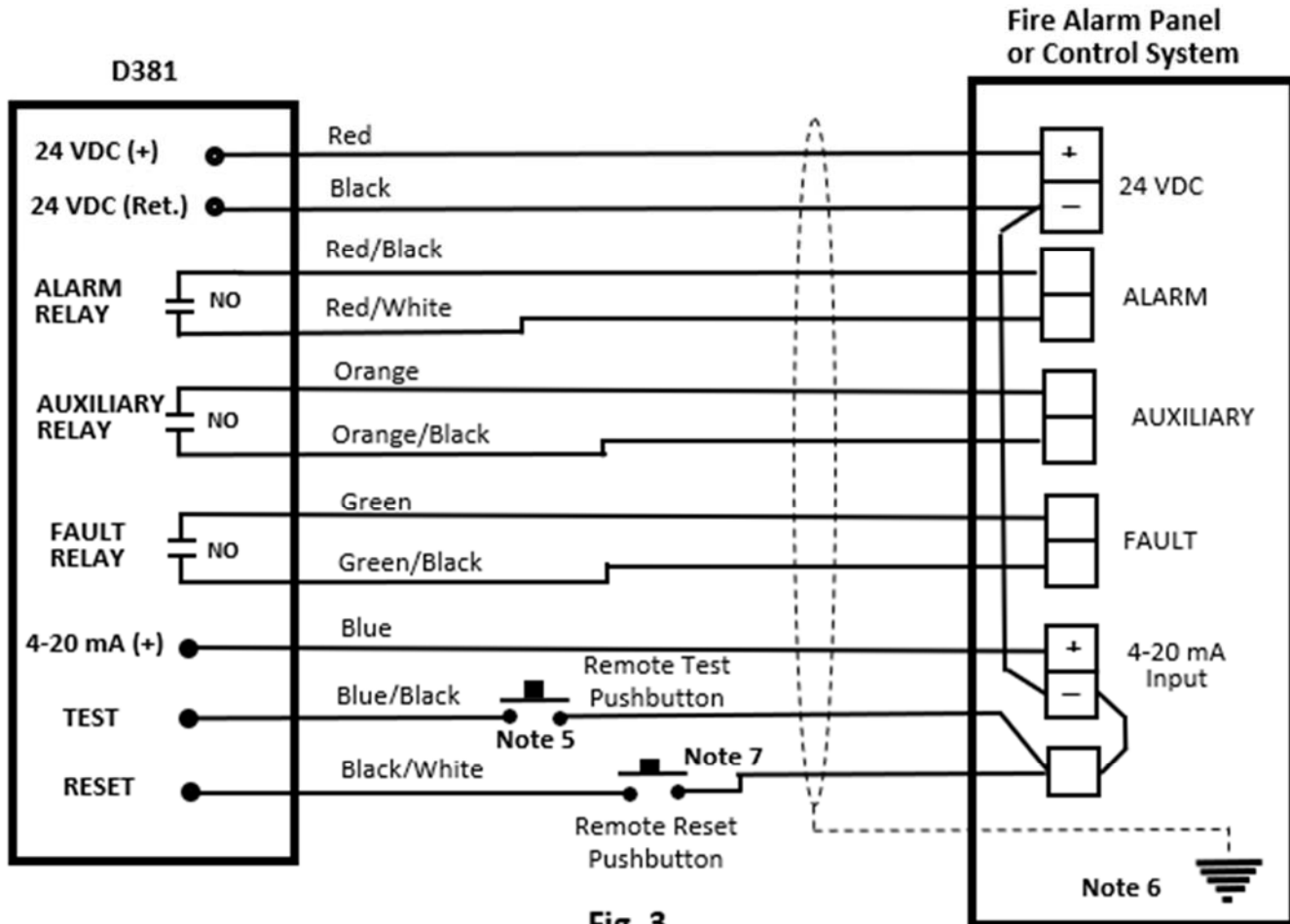
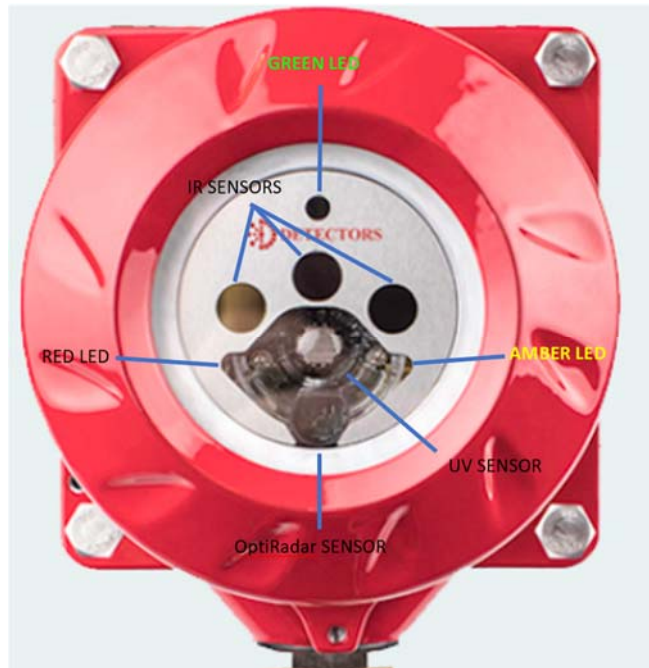

**Fig. 3**  
**Basic Detector Wiring**

### NOTES:

1. Relay contacts shown above are with no power applied to detector.
2. Power applied to detector and no ALARM: Fire Alarm and Auxiliary relays are normally De-Energized with N.O. Contacts. Both relays will energize and contacts close when detector in Alarm.
3. Factory setting for the Auxiliary relay is 3 seconds.
4. Power applied to detector and No FAULT: Fault relay will Energize and contact closes. When a fault is detected, Fault relay will De-Energize and relay contact will open. Fault relay will Energize automatically when Fault is removed.
5. Connecting wire labeled "Test" to 24 VDC (Return) will initiate detector's automatic self-test feature. Detector will cycle through its self-test checking the sensors and activating the relays and verifying through-the-lens test.
6. Cable shield must be connected to "Earth Ground" at one location only preferably at the panel.
7. Connecting the terminal labeled "Reset" to 24 VDC (Return) will reset the detector to Normal Operation. A momentary switch may be installed in the Control Center for resetting detector.

### 3.0 Detector Sensors, LED Indicators and Conduit Entry Location



## 4.0 Operation & Start-Up

### 4.1 Detector Performance & Response

The **D381** is a Multi-Spectrum UV/IR/IR medium range flame detector optimized for use in variety of indoor/outdoor applications in Class I, Division 2 area installations the detector includes a highly sensitive UV sensor and 3 separate Quantum IR sensors tuned precisely to 3 separate bands of IR radiation in the electromagnetic spectrum for responding to various types of fires. The detector will respond to both Hydrocarbon and Non-Hydrocarbon within 3-5 seconds, the response time will depend on the size of the flame, type of fuel, and the distance from the flame.

### 4.2 Detector Operation

Once powered up, the **D381** detector will go through its self-diagnostics process and will be ready for operation after 10-12 seconds. During the self-diagnostic process, the Green, Amber, and Red LEDs will turn on sequentially indicating this process. During the self-diagnostics, the Microprocessor will check the status of UV and IR sensors, relays, various devices, and the self-test feature. Once the Microprocessor determines that all devices and functions have been tested and found to be within the specifications, it will then terminate the self-test diagnostics and will return the detector to normal operation. During the normal operation, the Green LED will be turn "ON" for 1 second and "OFF" for 1 second indicating that the detector is now ready to detect fires.

### 4.3 Detector Visual Status Indications

The **D381** detector has (3) bright LEDs for indicating the status of the detector:

<b>Green LED</b>	Normal Operation
<b>RED LED</b>	Alarm Condition
<b>Amber LED</b>	Fault condition

#### 4.3.1 Normal Operation:

During the normal operation and with no Alarm or Fault existing, the detector will turn the Green LED "ON" for 1 second and "OFF" for 1 second indicating normal status. Unless otherwise specified the detector will be shipped with the following standard factory output configuration with power applied:

Alarm relay	Normally De-Energized, N.O. Contacts
Auxiliary relay	Normally De-Energized, N.O. Contacts
Fault relay	Normally Energized, N.C. Contacts
Analog output	4.0 +/- 0.2 mA – Normal operation
Relay modes	Non-Latching



#### 4.3.2 Alarm Condition:

When the **D381** detector is exposed to fires and declares an Alarm, the following conditions will occur (with standard factory configurations):

Red Alarm LED	Will turn "ON" steady
Green LED	Will continue flashing "ON" and "OFF"
Alarm relay	Will be activated
Auxiliary relay	Will be activated
Fault relay	Will remain unchanged
Analog output	20.0 +/- 0.2 mA
ModBus output	Will declare "Alarm" command

Please note that the Red Alarm LED will remain "ON" and the Alarm relay will remain Energized as long the fire is present. Once the fire has been extinguished the detector status will be as follows:

- a) **Non-Latching Alarm Relay mode:** The detector will automatically reset itself by De-Energizing the Alarm and Auxiliary Relays, turning off the Red LED, switching the analog output to 4 mA and removing the Alarm command from ModBus output
- b) **Latching Alarm Relay mode:** The detector status will remain unchanged with Alarm and Auxiliary relays still Energized and the Red Alarm LED remaining "ON" until the detector is reset by recycling the 24 VDC power to detector momentarily. The detector should now return to Normal operation.

#### 4.3.3 Fault Condition:

A Fault may occur if one or more of the following conditions exist (with standard factory configurations):

- Faulty UV or IR Sensor
- Faulty Microprocessor
- Faulty Relay
- Low input power (less than 19 VDC)
- High input power (higher than 34 VDC)
- High temperature
- Dirty viewing window
- Blockage of detector's window

During detector Fault the following conditions will occur (with standard factory configurations):

Amber LED	Will turn "ON" steady
Green LED	Will continue flashing "ON" and "OFF"
Fault relay	Will be De-Energized (deactivated)
Analog output	2.0 +/- 0.2 mA – Dirty Window
Analog output	0.3 – 0.9 mA – Other Faults
ModBus output	Will declare "Fault" Command

- a) **Non-Latching Fault Relay mode:** When the Fault has been cleared, the detector will automatically reset itself by turning off the Amber LED and Energizing the Fault relay.
- b) **Latching Fault Relay mode:** The detector status will remain unchanged with Fault relay still De-Energized and the Amber Fault LED remaining “ON” until the detector is reset by recycling the 24 VDC power to detector momentarily.

#### 4.3.4 Detector Automatic Self-Test:

The **D381** detector is programmed to perform an automatic diagnostic self-test periodically (factory default is every 5 minutes). During the automatic Self-Test, the detector will turn on both Amber LEDs flashing for several seconds indicating the self-test process. During the self-test process, the detector will turn on its internal UV and IR test sources momentarily which will be reflected from the Sapphire window back into the UV and IR sensors for analysis. Following the automatic Self-Test, the detector will return to Normal Operation if no Fault was detected.

#### 4.3.5 Detector Optical Path Test:

The detector also monitors the cleanliness of its viewing window and blockage of its viewing window every second using the **OptiRadar** feature. If the contamination of the window exceeds the preset threshold, the detector will declare a Fault. The detector also monitors the blockage of the window by external objects. If an object is placed within 1” of detector’s window, the detector will turn on its Amber light flashing for 60 seconds; and if the blockage is not removed after 60 seconds, the detector will declare a Fault by changing the flashing Amber light to steady on.

## 5.0 Maintenance

### 5.1 Inspection and Cleaning

Once the detector has been installed and powered up, it should provide maintenance free performance for years. The following is a simple guideline for keeping the detector working and trouble free:

**5.1.1** The **D381** detector requires no field calibration or adjustment.

**5.1.2** The detector and the viewing window should be kept clean from dirt, dust, oil and other contaminants at all times. Disconnect power before cleaning the detector’s window. To remove dirt and dust use soft cotton and soapy water and rinse the window with clean water. A soft cloth and IPA (Isopropyl Alcohol) can be used to remove oil and other residues from the window.

### 5.2 Detector Testing Procedure

**5.2.1 Periodic Testing:** The detector should be functionally tested end-to-end annually or as required by local codes or authorities having jurisdiction. Prior to testing the system, all detector outputs to Fire Alarm Panel or extinguishing systems should be disabled or disconnected. The functional test should be performed by qualified personnel being familiar with the system.

**5.2.2 Manual Test:** In addition to the continuous Automatic Self-Test, the **D381** detectors can be tested manually on a periodic basis. Referring to Fig. 3, Detector Wiring Schematic, the manual test can be initiated by momentarily connecting wire Blue/Black (Test) to 24 VDC (return) of power supply. To facilitate the manual test, A momentary pushbutton switch can be installed and located at the Fire Alarm panel or Control Center.

## 6.0 D381 Detector Response Characteristics

### 6.1 Performance Testing

The D381 detector, like any other flame detectors, will respond to various types of fires differently both in time and distance. For this reason, the Factory Mutual (FM) baseline performance testing is performed for all flame detectors using 1ft. x 1ft. n-Heptane pan fire for fuel fires and 30"-36" high plume fire for gas flames. This procedure would allow the end-users a means of comparing the flame detectors of various manufacturers for response time and sensitivity. Below is the response characteristic of the D381 detector as tested and witnessed by FM:

**Table 2 – D381 Detector Response @ High Sensitivity - Indoor**

Fuel Type	Flame Size	Distance (ft / m)	Response Seconds (Average)
n-Heptane	2" Dia.	11.75 / 3.6	3.2
n-Heptane	12" x 12"	80 / 24.4	5.4
IPA	12" x 12"	80 / 24.4	4.2
JP4	12" x 12"	40 / 12.2	5.7
Hydrogen	36" plume	60 / 18.3	4.7

### 6.2 Immunity to False Alarm Sources

Detector D381 is highly immune to many false alarm sources tested. Below tables are samples of False Alarm Immunity to various sources and the detector response time in the presence of false alarm sources:

**Table 3 – D381 Detector False Alarm Immunity @ High Sensitivity**

False Alarm Source	Distance	Unmodulated	Modulate
Sunlight	-	No Response	No Response
Incandescent Lamp – 60W	3ft / 0.91m	No Response	No Response
Infrared Heater – 1500W	3ft / 0.91m	No Response	No Response
Sodium Vapor Lamp – 150W	3ft / 0.91m	No Response	No Response
Florescent Lamp – 22W	3ft / 0.91m	No Response	No Response
Halogen Lamp – 500W	3ft / 0.91m	No Response	No Response
Mag Flashlight	3ft / 0.91m	No Response	No Response
Heater – 6kW	3ft / 0.91m	No Response	No Response
Arc Welding	30ft / 9.1	No Response	No Response

**Table 4 – D381 Detector Response in the Presence of False Alarm Source**

False Alarm Source	Fire Size and Fuel	Distance (ft./m)	Unmodulated Response Time Seconds (Ave.)	Modulate Response Time Seconds (Ave.)
Sunlight	12"x 12" n-Heptane	80/24.4	5.7	2.5
Incandescent Lamp – 60W	2" Dia. n-Heptane	9.75/2.97	2.7	3.3
Infrared Heater – 1500W	2" Dia. n-Heptane	9.75/2.97	2.5	2.3
Sodium Vapor Lamp	2" Dia. n-Heptane	9.75/2.97	3.9	1.6
Florescent Lamp	2" Dia. n-Heptane	9.75/2.97	3.8	3.0
Halogen Lamp – 500W	2" Dia. n-Heptane	9.75/2.97	3.5	7.3
Mag Flashlight	2" Dia. n-Heptane	9.75/2.97	2.8	2.9
Heater – 6kW	2" Dia. n-Heptane	9.75/2.97	2.9	2.8
Arc Welding	2" Dia. n-Heptane	30/9.1	10.0	10.4

## 7.0 Troubleshooting (to be added later)

## 8.0 Event Log & FireGraph (to be added later)

## 9.0 Accessories (to be added later)

## 10.0 Product Support

### 10.1 Technical Support and Customer Support

For Technical and Customer Support and questions concerning the detectors or applications, please contact:

Detectors Inc. Türkiye  
Bahcesehir 1. Kısım Mah. Dalgıckusu Cad.  
Defne 05 Ada 02 Villa  
Basaksehir / istanbul / Turkey



Tel : (0212) 944 57 00  
Email : info@detectorsincturkiye.com  
Web : www.detectorsincturkiye.com

## 11.0 Warranty

Detectors Incorporated warrants the products manufactured and supplied by Detectors Incorporated against defects in materials and workmanship under normal use and service for a period of five (5) years from the date of shipment. Detectors Incorporated at its sole discretion will repair or replace at no charge any products found to be defective during the warranty period. The defective product must be shipped transportation paid to Detectors Incorporated or Distributor/Representative where the products was purchased. This express limited warranty is extended by Detectors Incorporated to the original purchaser only and is not assignable or transferable to any other party.

This warranty does not cover the following:

1. Damage incurred in transit.
2. Defects or damage from misuse, accident, "Act of God", or neglect.
3. Defects or damage from improper installation, lack of maintenance, improper testing and operation.
4. Defects or damage caused by alterations, unauthorized dis-assemblies, repairs or modifications.
5. Damages caused by applying high voltage, electrical power surge or faulty power supplies.
6. Transportation charges to and from repair facility.
7. Illegal or unauthorized alterations of the firmware/software in the product.

This is the complete warranty for the products manufactured by Detectors Incorporated. Except for the warranty expressed above, Detectors Incorporated disclaims all other warranties express or implied with regards to its products sold. Detectors Incorporated sole liability under this warranty is limited only to repair or replacement of the products and shall not include any liability for consequential or other damages arising from the use of the product.

Detectors Inc. Türkiye  
Bahcesehir 1. Kısım Mah. Dalgıckusu Cad.  
Defne 05 Ada 02 Villa  
Basaksehir / İstanbul / Turkey



Tel : (0212) 944 57 00  
Email : info@detectorsincturkiye.com  
Web : www.detectorsincturkiye.com

## APPENDIX “A”

### D381 DETECTOR ORDERING INFORMATION

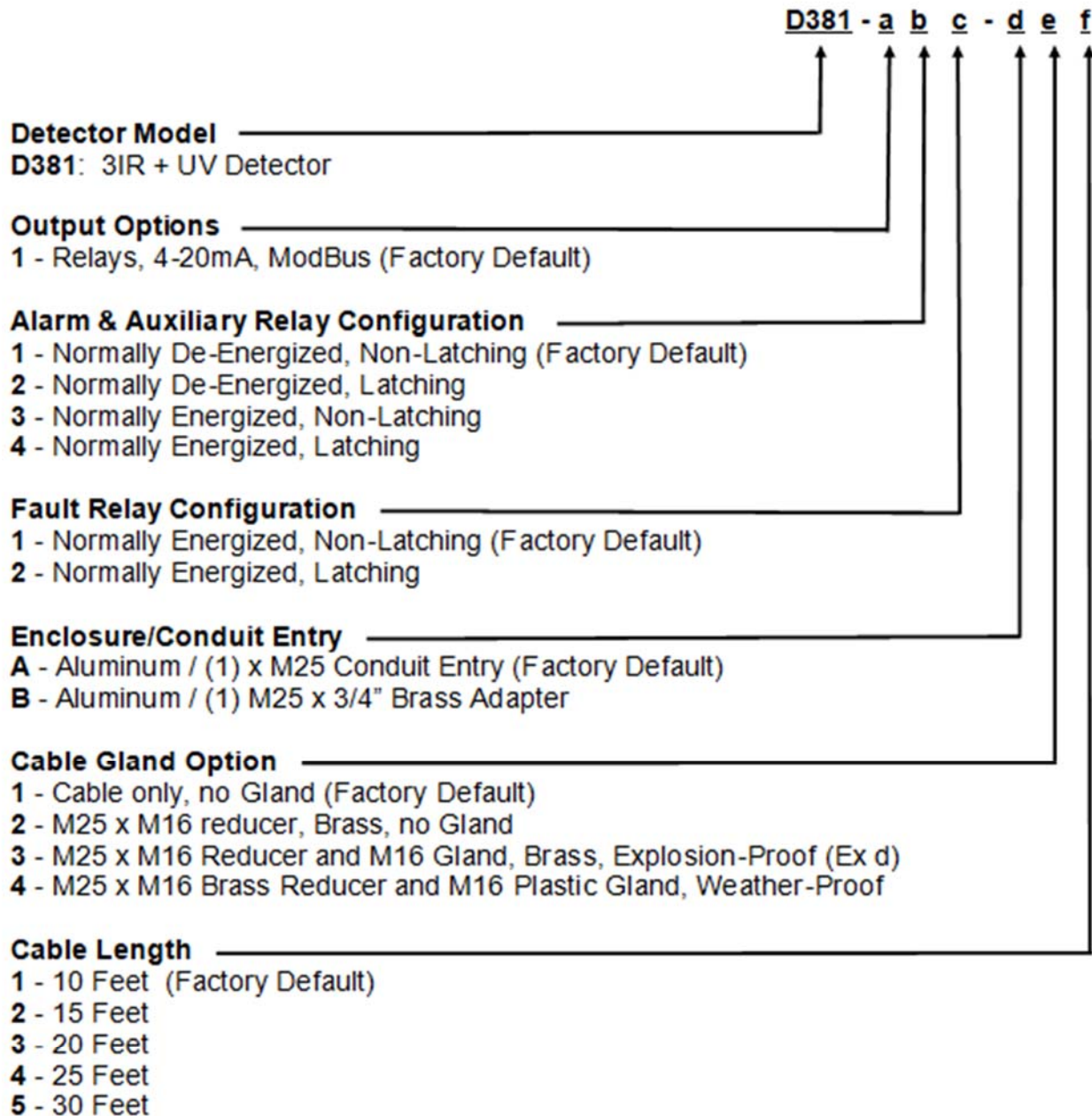

Example:     **D381-121-A11**  
 Detector with Relays & 4-20 mA outputs. Alarm and Auxiliary Relays Normally De-Energized Latching. Fault Relay Normally Energized Non-Latching. Aluminum Enclosure with (1) M25 Conduit Entry, No Cable Gland and 10-ft. Cable Length.

## APPENDIX “B”



Detectors Inc. Türkiye  
Bahcesehir 1. Kısım Mah. Dalgıckusu Cad.  
Defne 05 Ada 02 Villa  
Basaksehir / istanbul / Turkey



Tel : (0212) 944 57 00  
Email : info@detectorsincturkiye.com  
Web : www.detectorsincturkiye.com