



**DETECTORS**  
**INCORPORATED**  
*safety • security • peace of mind*

0212 944 57 00

info@detectorsturkiye.com

www.detectorsturkiye.com

## Model D371 SS 3IR + UV Flame Detector

### INSTRUCTION MANUAL



## Table of Contents

<b>INTRODUCTION</b> .....	3	<b>DETECTOR CONNECTIONS</b> .....	14
Product Description.....	3	Wiring Connections.....	14
Specifications.....	4	M25 Conduit Entries.....	14
Electrical.....	4	Connector Plugs J1 and J2.....	15
Environmental.....	4	Wiring Schematic.....	15,16
Mechanical.....	4		
Detector Sensors, LED		<b>OPERATION AND STARTUP</b> .....	17
Indicators and Connection.....	5	Powering the Detector.....	17
Equipment Label Certificate		LED Status Indicators.....	17,18
Numbers and Hazardous Location Ratings.....	6, 7	Detector Self-Test.....	18
		Alarm Test.....	19
<b>INSTALLATION</b> .....	8		
<b>CONDITION OF USE/GUIDELINE</b> .....	8	<b>MAINTAINANCE</b> .....	19
The Proper Detector.....	8	<b>Maintenance Requirements</b> .....	19
Field-of-View.....	8, 9	Detector Inspection.....	19
Positioning.....	9	<b>Periodic Detector Testing</b> .....	20
Sensitivity Settings.....	9	Functional Testing.....	20
Environmental Conditions.....	10	Inspecting the Wiring Compartment.....	20
Wiring.....	10		
<b>DETECTOR DIMENSIONS</b> .....	10	<b>D371 DETECTOR RESPONSE CHARACTERISTICS</b> .....	21
		<b>Performance Testing</b> .....	21,22
<b>MOUNTING THE DETECTOR</b> .....	11	<b>Immunity to False Alarms</b> .....	22,23
Swivel Arm Assembly			
(P/N: DA-001).....	11	<b>TROUBLESHOOTING (TO BE ADDED LATER)</b> .....	23
<b>DETECTOR OUTPUT SIGNALS</b> .....	11	<b>EVENT LOG &amp; FireGraph (TO BE ADDED LATER)</b> .....	24
Outputs.....	11	<b>ACCESSORIES (TO BE ADDED LATER)</b> .....	25
Relay Latching / Non-Latching.....	12	<b>PRODUCT SUPPORT</b> .....	25
4-20 mA Output.....	12	<b>Technical and Customer Support</b> .....	25
RS485 ModBus.....	12		
<b>CONFIGURING THE DETECTOR</b> .....	12	<b>WARRANTY</b> .....	26
Default Settings.....	12	<b>APPENDIX “A”-</b>	
Factory Default Relay Settings.....	12	<b>DETECTOR ORDERING INFORMATION</b> .....	27
<b>WIRING THE DETECTOR</b> .....	13	<b>APPENDIX “B”-</b>	
Wiring.....	13	<b>APPROVALS &amp; CERTIFICATIONS</b> .....	28
Conduit.....	13		
Cable Glands.....	13		
Shielded Cable.....	13		
Wire Gauge.....	13		

## 1.0 Introduction

### Model **D371SS** 3IR + UV



### 1.1 Product Description

The Model **D371SS** is a Multi-Spectrum 3IR + UV flame detector designed and optimized for detection of Hydrocarbon and Non-Hydrocarbon based fires while rejecting False Alarm Sources. The Model **D371SS** senses the IR radiation in 3 discrete bands of Infrared in the range of 2-5 microns.

The Model **D371SS** combines the benefits 3IR flame detector with the addition of a highly sensitive UV sensor for applications requiring a long-range UV/IR flame detector. The detector is offered in explosion-proof 316 stainless steel enclosures rated NEMA 4X / IP66 / IP67, as standard option. The **D371SS** detector can be used as stand-alone device or it can interface with any PLC or approved fire alarm panel.

*"D371SS Flame Detector includes a non-replaceable coin cell. Do not attempt to replace the coin cell at any time."*



## 1.2 Specifications

### 1.2.1 General

Field-of-View:	90° Horizontal, 90° Vertical
Spectral Sensitivity:	UV: 180-260 nanometers IR: 2-5 microns (3 discrete bands)
Sensitivity Setting:	High, Medium, Low
Response Time:	3-5 Seconds
Detection Range:	1' x 1' n-Heptane fire: Model <b>D371SS</b> : 200 ft. (61 m)

### 1.2.2 Electrical

Operating Voltage:	24 VDC nominal (18-31), Regulated
Power Consumption:	Standby: 60 mA @ 24 VDC Alarm: 90 mA @ 24 VDC Heater: 180 mA additional <b>(Heater is optional and must be specified when ordering)</b>
Relays Outputs:	Alarm / Fault / Auxiliary SPDT—contacts rated 2A @ 24 VDC Alarm & Auxiliary relays: De-Energized Fault relay: Energized Aux. relay settings: 0.3, 3, 10, 20 seconds <b>Factory Default for Aux. Relay: 3 Seconds</b>
Analog Output:	0-20 mA Stepped - Source
Communication:	RS485 ModBus RTU
Visual Indications:	<b>Green LED</b> - Normal <b>Red LED</b> - Alarm <b>Amber LED</b> - Fault
Conduit Entries	(2) M25 Optional M25 X 3/4" adapter available
Wiring:	12 AWG (3.3 mm <sup>2</sup> ) - 22 AWG (.33mm <sup>2</sup> )

### 1.2.3 Environmental

Humidity Range:	5 to 95% relative humidity, non-Condensing
Temperature Range:	-40 to + 185°F (-40 to + 85 °C) * -55 to 185°F (- 48.3 to + 85 °C) [with use of heater]
Enclosure Type:	NEMA 4 & 4X, IP66, IP67 * = Performance only, Does not apply to Hazardous Locations Approval

### 1.2.4 Mechanical

Enclosure Material:	316 Stainless Steel, Standard
Weight:	10 lbs. (4.5 kg)
Mounting:	Stainless Steel Swivel Arm—Optional
Weight:	6.6 lbs. (3 kg)

1.2.5 Detector Sensors, LED Indicators and Connections

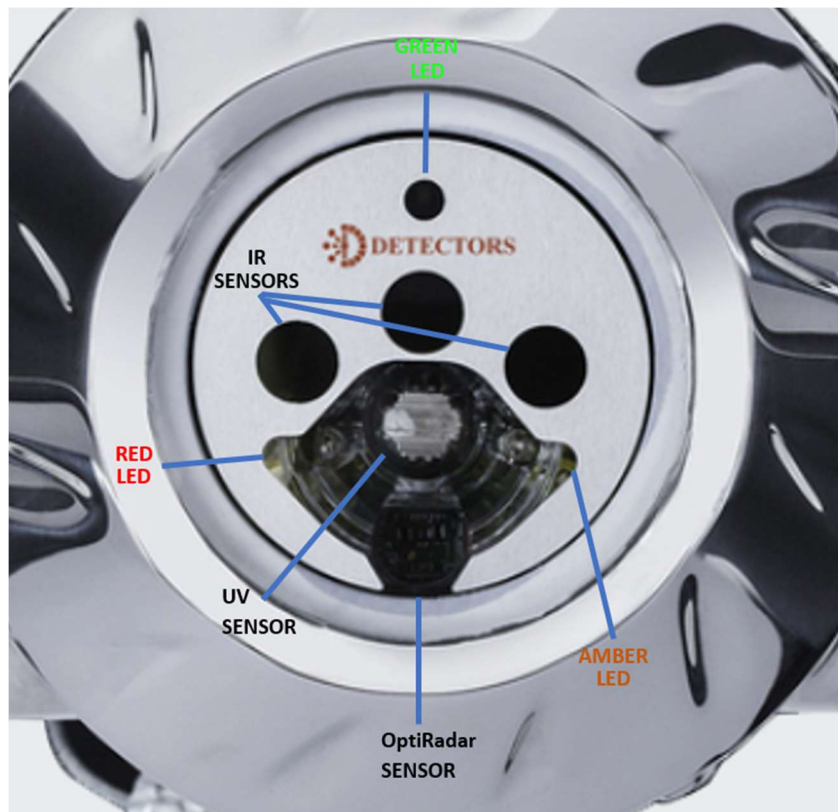

### 1.2.6 Equipment Label, Certificate #s and Hazardous Location ratings

1.2.6.1 Label: LAB-RANG-0006

Type	Ratings
Model #	D371SS-XXXX-NX
US	<p>FM17US0336X Class I, Division 1, Groups A, B, C, and D T6...T4 Ta=-40°C to Tx Class II/III, Division 1, Groups E, F and G T6...T4 Gb Ta=-40°C to +Tx</p> <p>Class I, Zone 1 AEx db IIC T6...T4 Gb Ta=-40°C to +Tx Zone 21 AEx tb IIIC T85°C...T135°C Db Ta=-40°C to Tx</p> <p>Type 4X and IP66/67</p> <p>For XP, DIP and AEx db, temperature code is T6 when Tx is +60°C, T5 when Tx is +75°C or T4 when Tx is +85°C</p> <p>For AEx tb, temperature code is T85°C when Tx is +60°C, T100°C when Tx is +75°C or T135°C when Tx is +85°C.</p> <p>Refer to installation instruction/manual</p>
Canada	<p>FM17CA0120X Class I, Division 1, Groups A, B, C, and D T6...T4 Ta=-40°C to Tx Class II/III, Division 1, Groups E, F and G T6...T4 Gb Ta=-40°C to +Tx</p> <p>Ex db IIC T6...T4 Gb Ta=-40°C to +Tx Ex tb IIIC T85°C...T135°C Db Ta =-40°C to +Tx</p> <p>Type 4X and IP 66/67</p> <p>For XP, DIP and Ex db, temperature code is T6 when Tx is +60°C, T5 when Tx is +75°C or T4 when Tx is +85°C</p> <p>For Ex tb, temperature code is T85°C when Tx is +60°C, T100°C when Tx is +75°C or T135°C when Tx is +85°C</p> <p>Refer to installation instruction/manual</p>
ATEX	<p>FM17ATEX0101X II 2 G Ex db IIC T6... T4 Gb Ta=-40°C to +Tx IP66/67</p> <p>For Ex db temperature code is T6 when Tx is +60°C, T5 when Tx is +75°C, T4 when Tx is +85°C</p> <p>For Ex db, temperature code is T85°C when Tx is +60°C, T100°C when Tx is +75°C or T135°C when Tx is +85°C</p> <p>Refer to Installation instruction/manual</p>
IECEX	<p>IECEX FMG 17.0034X Exdb IIC T6...T4 Gb Ta=-40° to +Tx Ex tb IIIC T85°C...T135°C Db Ta =-40°C to +Tx IP66/67</p> <p>T6 when Tx is +60°C, T5 when Tx is +75°C, T4 when Tx is +85°C</p> <p>T85°C when Tx is +60°C, T100°C when Tx is +75°C, T135 when Tx is +85°C</p> <p>Refer to installation instruction/manual</p>
CE	1725
Warning	<p>CAUTION: OPEN CIRCUIT BEFORE REMOVINF COVER ATTENTION: OUVRIER LE CIRCUIT AVANT DENLEVER LE COUVERCLE WARNING-DO NOT OPEN WHE AN EXPLOSIVE ATMOSPHERE IS PRESENT Ne Pas Ouvir En Prence Dune Atmosphere Explosive FOR DIVISIONS, SEAL CONDUIT WITHIN 450 mm OF ENCLOSURE For Zone installations, install a seal within 50mm of the enclosure Pour les zones Canadiennes, un scellement doit etre installe a mohs de 50mm du boiler WARNING-Do not open when energized or an explosive atmosphere is present</p>

1.2.6.2

Label: LAB-RANG-0008

Type	Ratings
Model #	D371SS-XXXX-MC
US	<p>FM17US0336X Class I, Division 1, Groups A, B, C, and D T6...T4 Ta=-40°C to Tx Class II/III, Division 1, Groups E, F and G T6...T4 Gb Ta=-40°C to +Tx</p> <p>Class I, Zone 1 AEx db IIC T6...T4 Gb Ta=-40°C to +Tx Zone 21 AEx tb IIIC T85°C...T135°C Db Ta=-40°C to Tx</p> <p>Type 4X and IP66/67</p> <p>For XP, DIP and AEx db, temperature code is T6 when Tx is +60°C, T5 when Tx is +75°C or T4 when Tx is +85°C</p> <p>For AEx tb, temperature code is T85°C when Tx is +60°C, T100°C when Tx is +75°C or T135°C when Tx is +85°C.</p> <p>Refer to installation instruction/manual</p>
Canada	<p>FM17CA0120X</p> <p>Ex db IIC T6...T4 Gb Ta=-40°C to +Tx Ex tb IIIC T85°C...T135°C Db Ta =-40°C to +Tx</p> <p>Type 4X and IP 66/67</p> <p>For XP, DIP and Ex db, temperature code is T6 when Tx is +60°C, T5 when Tx is +75°C or T4 when Tx is +85°C</p> <p>For Ex tb, temperature code is T85°C when Tx is +60°C, T100°C when Tx is +75°C or T135°C when Tx is +85°C</p> <p>Refer to installation instruction/manual</p>
ATEX	<p>FM17ATEX0101X II 2 G Ex db IIC T6... T4 Gb Ta=-40°C to +Tx IP66/67</p> <p>For Ex db temperature code is T6 when Tx is +60°C, T5 when Tx is +75°C, T4 when Tx is +85°C</p> <p>For Ex db, temperature code is T85°C when Tx is +60°C, T100°C when Tx is +75°C or T135°C when Tx is +85°C</p> <p>Refer to Installation instruction/manual</p>
IECEX	<p>IECEX FMG 17.0034X Exdb IIC T6...T4 Gb Ta=-40° to +Tx Ex tb IIIC T85°C...T135°C Db Ta =-40°C to +Tx IP66/67</p> <p>T6 when Tx is +60°C, T5 when Tx is +75°C, T4 when Tx is +85°C</p> <p>T85°C when Tx is +60°C, T100°C when Tx is +75°C, T135 when Tx is +85°C</p> <p>Refer to installation instruction/manual</p>
CE	1725
Warning	<p>CAUTION: OPEN CIRCUIT BEFORE REMOVINF COVER ATTENTION: OUVRIER LE CIRCUIT AVANT DENLEVER LE COUVERCLE WARNING-DO NOT OPEN WHE AN EXPLOSIVE ATMOSPHERE IS PRESENT Ne Pas Ouvir En Predence Dune Atmosphere Explosive FOR DIVISIONS, SEAL CONDUIT WITHIN 450 mm OF ENCLOSURE For Zone installations, install a seal within 50mm of the enclosure Pour les zones Canadiennes, un scellement doit etre installe a mohs de 50mm du boiler WARNING-Do not open when energized or an explosive atmosphere is present</p>

## 2.0 Installation

### 2.1 Specific Conditions of use:

**2.1.1** The **D371SS** IR3 with Enhanced UV Flame Detector Includes flamepath joints, consult with Detectors Inc if repair of the flamepath joints is necessary.

**2.1.2** The temperature code of the **D371SS** IR3 with Enhanced UV Flame Detector is based on the following maximum ambient temperatures

Temperature Codes (T-Codes)		Maximum Ambient Temperatures (Tx)
Gases/Vapors	Dust	
T6	T85°C	+60°C
T5	T100°C	+75°C
T4	T135°C	+85°C

### 2.1.3 Relevant Hazardous Locations Approval Standards

Standard Number	Description
EN 60079-0:20012 + A11 2013	Explosive atmospheres. Equipment. General requirements
EN 60079-1:2014	Explosive atmospheres. Equipment protection by flameproof enclosures "d"
EN 60079-31:2014	Explosive atmospheres. Equipment dust ignition protection by enclosure "t"
EN 60529:1991+A1:2000	Degrees of protection provided by enclosures (IP Code)
IEC 60079-0:2011	Explosive atmospheres - Part 0: Equipment - General requirements
IEC 60079-1:2014	Explosive atmospheres - Part 1: Equipment protection by flameproof enclosures "d"
IEC 60079-31:2013	Explosive atmospheres - Part 31: Equipment dust ignition protection by enclosure "t"

## 2.2 Guideline

There are several important factors that must be considered when installing flame detectors in order to optimize their performance. Below are the guidelines to be observed as a minimum:

### 2.2.1 The Proper Detector

Verify that you have purchased and received the right detector for your application. Survey the hazard area to ensure that there are adequate number of detectors for proper coverage. This is determined by the Field-of-View of detector, it's distance from the hazard area and the sensitivity setting. When in doubt, please contact the factory for additional information.

### 2.2.2 Field-of-View

Field-of-View (FOV) or cone of vision of a flame detector is a three-dimensional conical volume with the apex at the center of flame detector and extending outward. FOV is normally determined by the detector enclosure, size and shape of the window and the sensors placement. FOV from various manufacturers can vary from 70 -



120 degrees wide. A wide FOV does not necessarily mean the flame detector is better; different applications require different FOV for the area coverage. Smaller hazardous areas and certain applications require precise coverage so that the FOV of the detector does not extend beyond the area intended to be covered.

### 90° True Conical Field of View

#### Fire Response at Maximum Distance

Direction	Avg. Response Time (Seconds)
Horizontal ←	5.8
Horizontal →	5.9
Vertical ↓	5.8
Vertical ↑	5.5

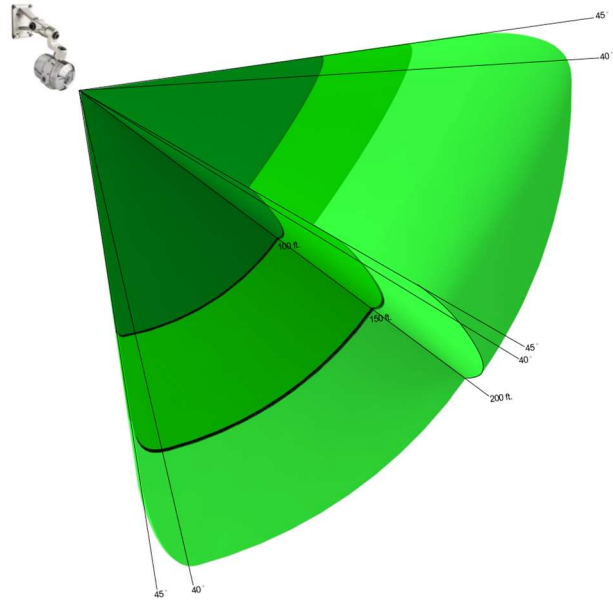

#### 2.2.3 Positioning

The detector should be installed such that the center of the detector is aimed at the center of the area to be protected (hazard area). Detectors should be installed above the hazard area pointing downward at an angle between 35-55 degrees from horizontal with no obstruction of the Field-of-View. Detector height generally should be approximately 1½ to 2½ times the height of tallest object in the hazard area. The height may vary depending on the application, indoor/outdoor installation and size of the hazard area. Detector should be easily accessible for maintenance.

#### 2.2.4 Sensitivity Settings

The Model **D371SS** detector has the following sensitivity settings and responses to 12" X 12" n-heptane pan fires within 3-5 seconds

**Table 1**

Sensitivity Setting	Distance
High	200 ft. (61 m)
Medium	150 ft. (38.1 m)
Low	100 ft. (22.9 m)

Detector sensitivity setting will depend on the size of the hazard area, distance from detector to hazard area, type of fuel, and size of the fire

### 2.2.5 Environmental Conditions

If possible, detectors should be installed so that they are protected from rain, snow, direct sunlight and other intense sources of IR or UV radiation. It is critical to protect the detector against ingress of moisture inside the enclosure. Detector's cover must be tightened per manufacturer's recommended procedure and the conduits openings must be properly sealed to prevent moisture from entering the enclosure.

### 2.2.6 Wiring

Approved shielded cable must be used to protect the electronics against interference from RFI and EMI. Generally, 18 or 16 gauge shielded cable is recommended. The wire size will depend on the distance from detector to the control system and the number of detectors connected to the same power source. Cable shield should be terminated at a ground lug near the detector.

**NOTE:** Supply field wiring must be rated at least 25°C greater than the maximum ambient temperature of the application.

## 2.3 Detector Dimensions

The **D371SS** detector is supplied with 316 Stainless Steel enclosure suitable for installation in Class I, Div. 1 (Zone 1) Hazardous areas. The enclosure is Water-Tight and rated NEMA 4 & 4X with ingress protection of IP67. The enclosure dimensions are as shown in Figure (1).

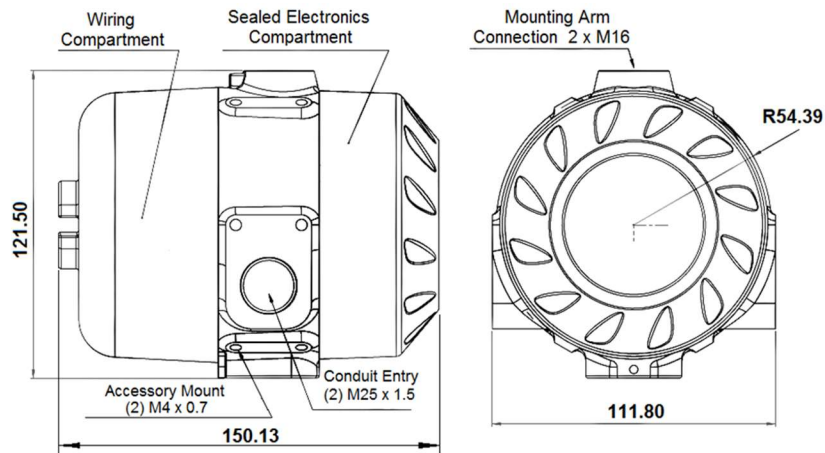

**Fig. 1**  
**Detector Dimensions** (Dimension in mm)

## 2.4 Mounting the Detector

Detector should be mounted on a rigid and vibration free surface using the Swivel Arm Assembly Model SM-37 (P/N: DA-001).

### 2.4.1 Swivel Arm Assembly (P/N: DA-001)

Swivel Arm assembly is fabricated from 316 stainless steel and shipped fully assembled. It consisted of three sections: mounting base, center piece, and detector holding piece. It has a ratchet design allowing detector rotation in vertical and horizontal planes.

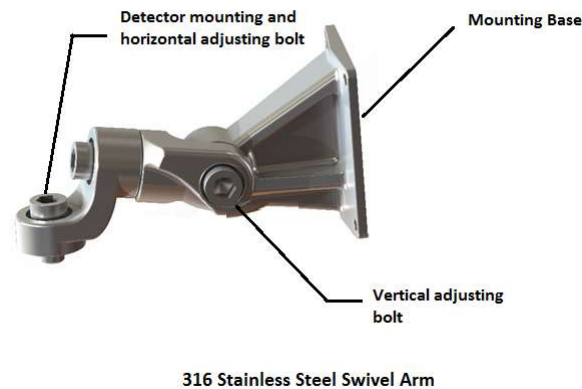

**Fig. 2 – Swivel Mounting Arm**

To install the Swivel Arm Assembly:

1. Unpack and inspect the Swivel Arm assembly.
2. Place the mounting base on a rigid and flat surface and secure it with (4) 7mm or 1/4" bolts of proper length (bolts not supplied).
3. Place the detector under the Swivel Arm assembly and secure it to the detector holding piece of the Swivels Arm assembly with an M16 bolt supplied with the Swivel Arm assembly, tighten the bolt.
4. Detector can now be adjusted vertically and horizontally by loosening the vertical and horizontal M16 bolts on the Swivel Arm assembly and aiming the detector to the hazard area.

## 2.5 Detector Output Signals

### 2.5.1 Outputs

The detector has the following outputs (no power applied):

- Fire Alarm Relay (SPDT) – Normally Open/Normally Closed
- Fault Relay (SPST) – Normally Open
- Auxiliary Relay (SPDT) – Normally Open/Normally Closed
- Analog output: 0-20 mA stepped
- RS-485 ModBus RTU

### 2.5.2 Relay Outputs: Latching / Non-latching

Detectors are shipped from factory with “Non-Latching” relays as factory standard. If “Latching” relays are required, must be specified when ordering. Please refer to Appendix “A” for optional configurations.

### 2.5.3 4-20mA Output

A non-isolated 0-20 mA stepped analog output (Current Source) is also provided as standard. Following output levels are defined:

**Table 2 - Analog Current output levels**

Analog Output (mA)	Detector Status
0.0	Fault - No Power
< 1.0	Fault - General
2.0 ± 0.3	Fault – self-test
4.0 ± 0.3	Normal (no alarm, no fault)
20.0 ± 0.3	Alarm

Maximum loop resistance for the analog output is 800 Ohms

### 2.5.4 RS485 ModBus Communication

The detector model **D371SS** is also equipped with a standard RS485 ModBus communication protocol for interfacing with devices or controllers using the Modbus standard. The RS485 communication protocol is also useful in communicating with the detectors for viewing or downloading Event Logs and Fire Charts using a laptop and the optional LabVIEW programming software available from Detectors Inc.

## 2.6 Configuring the Detector

### 2.6.1 Default Settings:

Unless specified, The **D371SS** detector is shipped factory configured as described below:

<b>Fire Alarm Relay:</b>	Normally De-Energized, Non-Latching (NO/NC)
<b>Fault Relay:</b>	Normally Energized, Non-Latching (NC)
<b>Auxiliary Relay</b>	Normally De-Energized, Non-Latching (NO/NC)
<b>4-20 mA</b>	Stepped Analog, Sourcing
<b>Communication</b>	ModBus RTU Protocol
<b>Sensitivity Setting</b>	High

### 2.6.2 Factory Default Relay Settings

All relays with standard configuration are “Non-Latching”. If “Latching” mode is required, it must be specified when ordering.

## 2.7 Wiring the Detector

### 2.7.1 Wiring

Detectors shall be wired in accordance with the local codes and standards for the area they are intended for.

Detector shall be wired in accordance with the current National Electrical Code (NFPA 70) for hazardous location wiring procedure in the United State; or according to the local codes in other countries, observing the requirements for Electrical Safety.

### 2.7.2 Conduit

If conduit is used, conduit type and installation in a Hazardous Area shall comply with the National Electric Code Standard, Article 500. For locations, other than the United States, use of conduit or cable glands shall comply with the local codes. Proper conduit sealing compound must be used to prevent ingress of moisture.

### 2.7.3 Cable Glands

If Cable Glands are used in Hazardous and Industrial areas, they should meet the North American and International codes and standards for such installations.

### 2.7.4 Shielded Cable

Shielded cable is highly recommended for protection against RFI and EMI. Where multiple detectors are installed, the wire size will depend on the number of detectors connected to a power supply and the length of cables and the supply voltage. The voltage at any given detector shall not be less than 18 VDC. Normally, 18 or 16-gauge (AWG) wire is adequate for short runs and fewer than 10-12 detectors.

### 2.7.5 Wire Gauge

Table below is a partial listing of the American Wire Gauge Property and Conductor Size. Using a power supply with 22-28 VDC output rating and the table below, calculations can be performed to obtain the allowable voltage drop across a selected wire gauge in order to maintain minimum of 18 V at each detector connected to the power supply.

**Table 3 - American Wire Gauge (AWG) and Properties Table**

AWG	Area (mm <sup>2</sup> )	Resistance Ohms/1000 ft.	Resistance Ohms/1000 m)
12	3.31	1.59	5.21
14	2.08	2.53	8.28
16	1.31	4.02	13.17
18	0.82	6.39	20.94
20	0.52	10.15	33.20

## 2.8 Detector Connections

### 2.8.1 Wiring Connections

Wiring connections are made to connectors inside the rear compartment. The detector has two separate compartments one in the front housing the detector electronics and one in the back containing the PC boards with connector terminal for wiring. Compartments are separated by a physical barrier in order to keep the electronics from being exposed to environment while wiring.

**NOTE:** For US Zones, the internal grounding terminal must be used. The external grounding terminal is supplementary.

**CAUTION:** The front cover should not be removed at any time. Removing the electronic module and tampering with the circuit board will void the detector warranty. Contact factory for detector configuration changes requiring access to DIP switches on the face of the detector.

### 2.8.2 M25 Conduit Entries

There are two M25 conduit entries located at the wiring compartment, one or both conduit entries may be used for routing the cable(s). If only one conduit entry is used, the unused conduit entry must be properly sealed with an approved sealing material similar to Teflon dope or tape. Metal-to-Metal will NOT provide adequate seal against the ingress of moisture. Simply remove the 25 mm plug, apply the sealing compound and re-install the plug to ensure a weather-tight integrity of the wiring compartment.

An M25 x 3/4" adapter will be supplied when 3/4" NPT connections are specified.

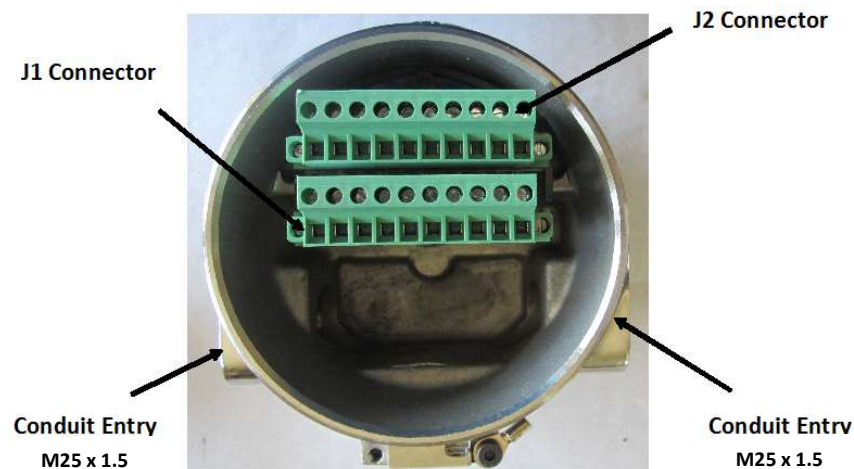

Rear Compartment of Detector with Cover Removed

Fig. 3

### **2.8.3 Connector Plugs J1 and J2**

The connector plugs J1 and J2 can be removed for wiring and re-installed once the wiring is completed. Please note that there are 24VDC(+) and 24VDC(-) terminals on each connector. These terminals are internally connected and the power may be connected to one connector plug only.

### **2.8.4 Wiring Schematic**

A typical wiring schematic for **D371SS** detector is shown in Figure (4)

Fig. 4 –Detector Wiring Schematic

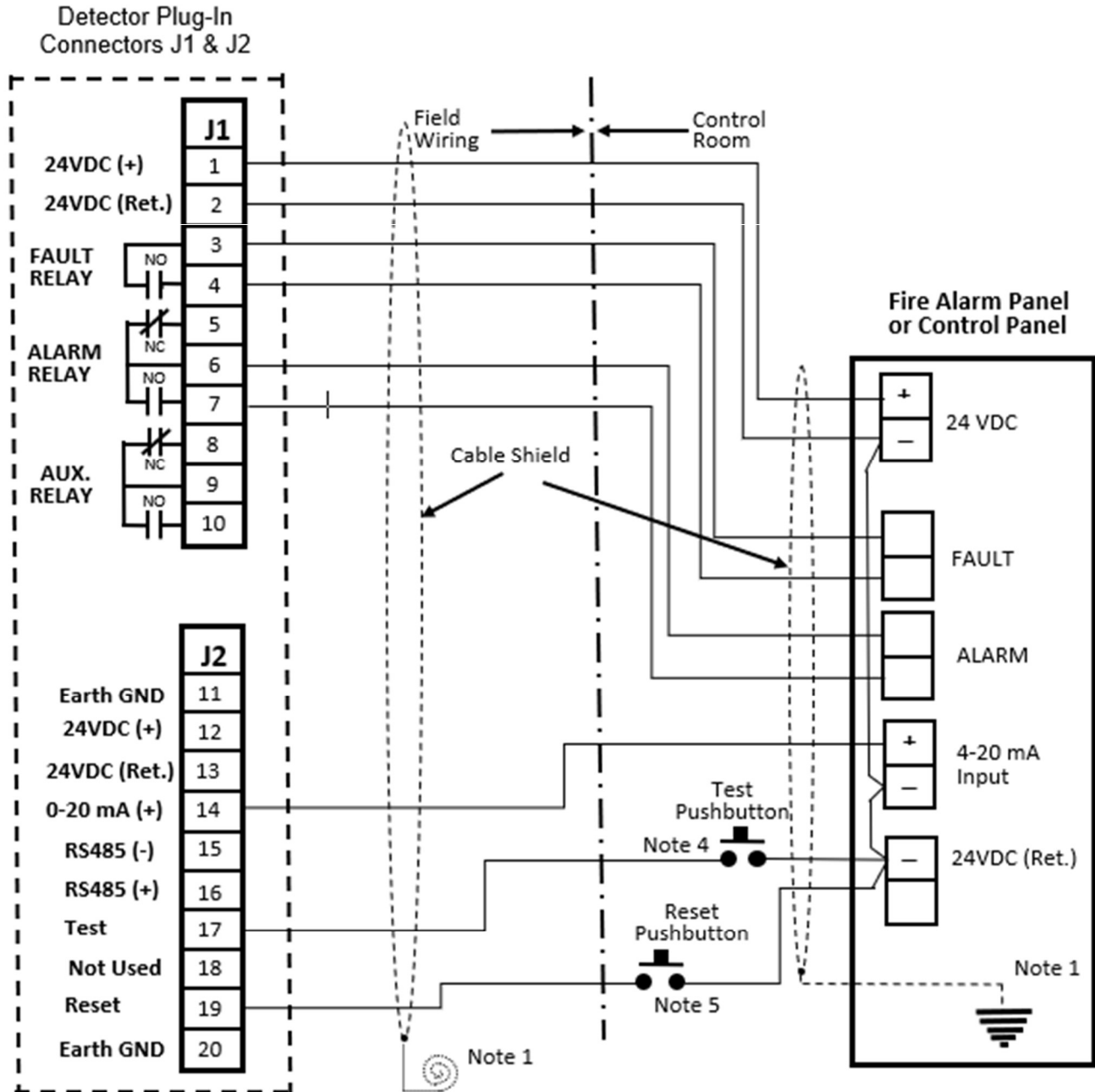

NOTES:

1. Cable shield must be connected to "Earth Ground" at one location preferably at the Fire Alarm or Control Panel only. Coil and tape the cable shield at the detector end.
2. Detector enclosure must be connected to "Earth Ground" at the detector location.
3. All relay contacts shown in static condition with no power applied to detector. When power is applied, Fire and Auxiliary relays will remain De-Energized and Fault relay will energize with contacts closed and no Fault.
4. Connecting or shorting terminal labeled "Test" to 24 VDC (Return) will initiate detector's automatic self-test feature. Detector will cycle through its self-test checking the sensors, energizing Fire/Aux. relays, and verifying through-the-lens test. A momentary switch may be installed in the Control Center for Testing the detector. **Caution:** All relay outputs to Control Panel and extinguishing systems must be disabled to prevent system alarms and unwanted extinguishing discharge.
5. Connecting or shorting terminal labeled "Reset" to 24 VDC (Return) will recycle power resetting the detector to Normal Operation. A momentary switch may be installed in the Control Center for Resetting the detector.

## 3.0 Operation & Startup

### 3.1 Powering the Detector

**3.1.1** Once the installation of the detector and wiring are completed, the next step is to power up each detector individually and perform functional tests by generating Fire Alarm and Fault conditions.

**NOTE:** *When performing functional tests during the start-up or maintenance always check to make sure that the output of the detector to fire suppression systems has been disabled.*

**CAUTION:** *When performing functional tests during the start-up or maintenance always check to make sure that the output of the detector to fire suppression systems has been disabled.*

#### 3.1.2 LED Status Indicators

Apply power to the detector and wait 1-2 minutes until the detector has completed its diagnostic process and its circuitry has been stabilized. During this process detector LEDs will flash sequentially clockwise several times; once normalized its green LED will remain ON for one second and OFF for one second indicating normal operation.

The detector status is indicated by 3 color LEDs as follows:

**Normal Operation:** The Green LED will turn ON and OFF every second indicating that the detector is operating properly and there is no Fault or Alarm. If the Green light is not flashing, please check wiring or the 24 VDC power to the detector.

**Fault Condition:** The Amber LED will turn on and stay on when either a General Fault or Self-Test Fault is detected. The detector will return to Normal when Fault is cleared, and the Amber LED will turn off automatically.



**Alarm Condition:** The Red LED will turn on indicating that the detector has detected fire. The Red LED will remain on as long as the fire is present and will turn off once the fire has been extinguished. The detector status will then return to Normal Condition with the Green LED flashing



### 3.1.3 Detector Self-Test:

The **D371SS** detector is programmed to perform an automatic diagnostic self-test periodically (factory default is every 5 minutes). During the automatic Self-Test, the detector will turn on both Amber LEDs flashing for 2-3 seconds. Following the automatic Self-Test, the detector will return to Normal Operation if no Faults were detected. The detector will also monitor the blockage of its viewing window every second using the **OptiRadar** feature. If any object is placed within 2" of detector's window for longer than 60 seconds, the detector will declare a Fault.



### 3.1.4 Alarm Test Using the Manual Self-Test

Fire Alarm Test: This test can be done by forcing the detector into its Self-Test Mode. This can be accomplished by connecting (shorting) the terminal #7 of the J2 connector to 24VDC (-) until the Red LED is turned on (Fig. 4, Page 14). **Caution: All relay outputs to Control Panel and extinguishing systems must be disabled to prevent system alarms and unwanted extinguishing discharge.**

1. **Detector with “Latching” configuration** - Once in Alarm, 24 VDC(-) should be removed from terminal #7. The detector, however; will remain in Alarm mode until it is reset by momentarily recycling power to detector. To reset the detector simply connect (or short) the terminal #9 of the J2 connector to 24 VDC (-). The detector will then return to Normal.
2. **Detector with “Non-Latching” configuration** - Once the detector is in Alarm, removing 24 VDC(-) from terminal #7 (J2) return the detector automatically to Normal within 5 seconds.

## 4.0 Maintenance

### 4.1 Maintenance Requirements

#### 4.1.1 Detector Inspection

The **D371SS** detector does not require calibration at any times after installation. This detector also is not easily affected by dirt, dust, smoke, water and even thin layer of ice built-up on the lens. To maintain the detectors in best working condition and performance it is recommended to inspect and clean the detector periodically. It is very important to keep the detector lens (window) cleaned particularly in heavy industrial facilities and dirty environments. Contaminants such as dirt and oil on the lens may attenuate some of the UV and IR radiation lowering the detector’s sensitivity. The following is a routine maintenance guideline:

1. Inspect and clean the lens once every 6 months in a clean environment or more often in dirty environments.
2. The detector lens is made of Sapphire and thus care should be taken not to use any harsh chemicals or scratcher pads to clean it. A simple cotton cloth or cotton balls using water and mild detergent will be the best option. If oil has accumulated on the lens, use a small amount of IPA solution (Isopropyl Alcohol) and a cotton ball or clean cloth to clean the lens.

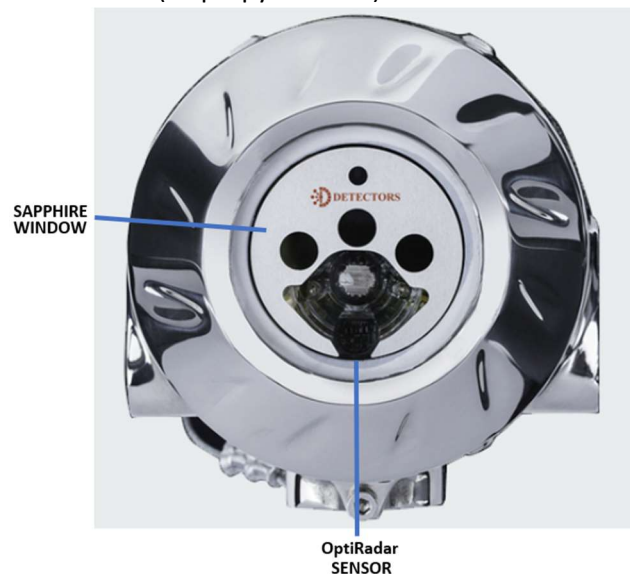

3. Unlike the conventional flame detectors, The **D371SS** has no external reflector or reflector ring for reflecting the IR or UV test source generated by the detector back onto the IR or UV sensors for determining the obscuration due to the build-up of contaminants on the lens. The detector uses its Sapphire window as a “reflector” for self-test purposes and its **OptiRadar** feature to determine the obscuration of the window. The detector will initiate a self-test FAULT if excessive amount of dirt, dust, oil other contaminants accumulate on the lens. Should the contamination on the lens exceed the allowable threshold, the detector will initiate a self-test FAULT.

## 4.2 Periodic Detector Testing

### 4.2.1 Functional Testing

Every detector should be functionally tested at least once every 6 to 12 months or as required by the local authorities having jurisdiction. This shall include but not limited a complete “end-to-end test” of all detectors and verifying that all relays and output signals perform per manufacturer’s original Specifications. The detector can be put into Alarm mode as described in Section 3.1.4 and should be used for testing as follows:

1. **Caution: Prior to performing the fire test, ensure that all extinguishing systems are disabled or bypassed.** Follow the procedure outline in Section 3.1.4 forcing the detector into Alarm. Detector’s output signals should be monitored to verify that they are functioning properly.
2. A Fault test can be performed by forcing the detector into a Fault condition. This can be accomplished by lowering the input voltage to the detector to below 18 volts (low voltage fault) and monitoring the status of the Fault relay and Fault LED.

To perform a self-test Fault using the **OptiRadar** feature built into the detector, place a small piece of opaque material such as thin cardboard directly in front of the Window thus blocking the detector’s view. The detector’s Amber LED (Fault) will begin flashing for 60 seconds indicating blockage of the viewing window. Holding the cardboard longer than 60 seconds will turn the flashing Amber LED to steady Amber LED indicating the detector has failed the self- test and has declared a Fault.

### 4.2.2 Inspecting the Wiring Compartment

In locations with high humidity and rainfall it is recommended to open the back cover and visually inspect inside of the wiring compartment for possible ingress of moisture, clean if needed. Inspect the threads on both the enclosure and the cover. Clean and apply a small amount of Lithium-based grease to keep the threads lubricated. Re-Close the cover and tighten it to the manufacturer’s recommended torque 5-10 ft.-lbs.

## 5.0 D371SS Detector Response Characteristics

### 5.1 Performance Testing

The **D371SS** detector, like any other flame detectors, will respond to various types of fires differently both in time and distance. For this reason, the Factory Mutual (FM) baseline performance testing is performed for all flame detectors using 1ft. x 1ft. n-Heptane pan fire for fuel fires and 30"-36" high plume fire for gas flames. This procedure would allow the end-users a means of comparing the flame detectors of various manufacturers for response time and sensitivity. Below is the response characteristic of the **D371SS** detector as tested and witnessed by FM:

**Table 4: Detector Response @ High Sensitivity - Outdoor**

Fuel Type	Flame Size (ft)	Distance (ft / m)	Response - Seconds (Average)
n-Heptane	1' x 1'	200 / 61	7.0
n-Heptane	2' x 2'	300 / 91	7.0
IPA	1' x 1'	160 / 49	7.7
Ethanol	1' x 1'	150 / 45.7	6.4
Methanol	1' x 1'	130 / 39.6	7.7
87 Octane	1' x 1'	180 / 54.9	7.4
JP4	1' x 1'	160 / 49	7.2
Diesel	1' x 1'	180 / 54.9	8.1
JP8	1' x 1'	180 / 54.9	6.7
Methane	36" plume	180 / 54.9	6.3
Ethylene	36" plume	180 / 54.9	6.0
Hydrogen	36" plume	100 / 30.5	5.9

\*Gas fire orifice size: 3/8"

**Table 5: Detector Response @ Medium Sensitivity - Outdoor**

Fuel Type	Flame Size (ft)	Distance (ft / m)	Response - Seconds (Average)
n-Heptane	1' x 1'	150 / 45.7	6.6
IPA	1' x 1'	120 / 36.6	9.1
Ethanol	1' x 1'	120 / 36.6	12.0
Methanol	1' x 1'	70 / 21.3	7.6
87 Octane	1' x 1'	130 / 39.6	7.5
JP4	1' x 1'	120 / 36.6	7.1
Diesel	1' x 1'	120 / 36.6	17.4
JP8	1' x 1'	130 / 39.6	7.3
Methane	36" plume	130 / 39.6	7.3
Ethylene	36" plume	150 / 45.7	8.6
Hydrogen	36" plume	20 / 6.1	8.1

\*Gas fire orifice size: 3/8"

**Table 6: Detector Response @ Low Sensitivity - Outdoor**

Fuel Type	Flame Size (ft)	Distance (ft / m)	Response - Seconds (Average)
n-Heptane	1' x 1'	100 / 30.5	7.8
IPA	1' x 1'	80 / 24.4	7.5
Ethanol	1' x 1'	70 / 21.4	7.9
Methanol	1' x 1'	40 / 12.2	11.0
87 Octane	1' x 1'	100 / 30.5	7.3
JP4	1' x 1'	80 / 24.4	8.0
Diesel	1' x 1'	70 / 21.4	10.0
JP8	1' x 1'	80 / 24.4	9.2
Methane	36" plume	100 / 30.5	9.8
Ethylene	36" plume	100 / 30.5	7.4
Hydrogen	36" plume	20 / 6.1	9.22

\*Gas fire orifice size: 3/8"

## 5.2 Immunity to False Alarm Sources

Detector **D371SS** is highly immune to many false alarm sources tested. Below tables are samples of False Alarm Immunity to various sources and the detector response in the presence of false alarm sources:

**Table 7: Immunity to False Alarm Sources**

False Alarm Source	Device Status	Distance (ft / m)
Incandescent Lamp - Solid	Immune	3 / .90
Incandescent Lamp – Modulated	Immune	3 / .90
1500 W Heater – Solid	Immune	3 / .90
1500 W Heater – Modulated	Immune	3 / .90
Sodium Vapor Lamp – Solid	Immune	3 / .90
Sodium Vapor – Modulated	Immune	3 / .90
Fluorescent Lamp - Solid	Immune	3 / .90
Fluorescent Lamp - Modulated	Immune	3 / .90
500 W Halogen – Solid	Immune	3 / .90
500 W Halogen – Modulated	Immune	3 / .90
Mag Light - Solid	Immune	3 / .90
Mag Light – Modulated	Immune	3 / .90
Outdoor Direct Sun – Solid	Immune	--
Outdoor Direct Sun - Modulated	Immune	--
Outdoor Indirect Sun – Solid	Immune	--
Outdoor Indirect Sun - Modulated	Immune	--
Arc Welding – Solid	Immune	9 / 2.7
Arc Welding Solid	Immune	9 / 2.7

### 5.3 Fire Response in the presence of False Sources

The **D371SS** detector, like any other flame detectors, is exposed to various false source throughout the life of the product. For this reason, the Factory Mutual (FM) testing is performed for all flame detectors using specific sources known to cause unwanted and spurious alarms. Additionally, these same false sources have also been known to impact the operation of the devices and inhibit the devices ability to detect fire while they are present. This procedure would allow the end-users a means of comparing the flame detectors of various manufacturers for the ability to respond to a fire in the presence of the most common false sources. Below is the response characteristic of the **D371SS** detector as tested and witnessed by FM:

**Table 8: Detector Response to Fire in the Presence of False Sources @ High Sensitivity**

False Alarm Source	False Source Distance (ft / m)	Average Response Time to a Reference Fire
Incandescent Lamp - Solid	3 / .90	6.2
Incandescent Lamp – Modulated	3 / .90	8.4
1500 W Heater – Solid	3 / .90	5.7
1500 W Heater – Modulated	9 /	5.5
Sodium Vapor Lamp – Solid	3 / .90	5.9
Sodium Vapor – Modulated	3 / .90	5.8
Fluorescent Lamp - Solid	3 / .90	6.0
Fluorescent Lamp - Modulated	3 / .90	5.8
500 W Halogen – Solid	3 / .90	5.9
500 W Halogen – Modulated	6 / 1.8	8.5
Mag Light – Solid	3 / .90	6.3
Mag Light – Modulated	3 / .90	6.7
Outdoor Direct Sun – Solid	--	5.8
Outdoor Direct Sun - Modulated	--	9.4
Outdoor Indirect Sun – Solid	--	5.6
Outdoor Indirect Sun - Modulated	--	6.0
Arc Welding – Solid	9 / 2.7	5.3
Arc Welding Solid	9 / 2.7	4.0

### 6.0 Troubleshooting (to be added later)



## 7.0 Event Log & Fire Graph

### 7.1 Fire Graph

The Fire Graph is a digital representation of the optical data viewed by the detectors at the time of the alarm. The Fire Graph consists of data 4 seconds prior to the alarm and 6 seconds after the alarm.

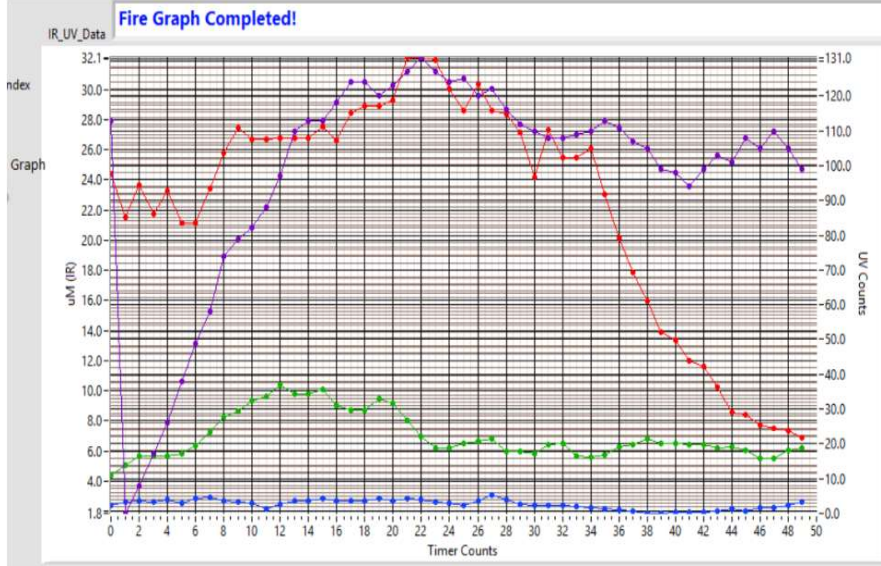

### 7.2 Event Log

The Event Log is a record of 200 consistent events. This list uses a First in First out (FIFO) logic when recording events. A event is categorized by the D371SS device and any Power cycle, Fault, Failed internal diagnostic result, or an alarm condition.

Column1	Column2
Power On- 2018 . 10 . 29 . 19 : 3	Power Off: 2018 . 10 . 29 . 19 : 16 .
Fire Event- 2018 . 8 . 30 . 19 : 33 : 42 Temp=41.17 °C, Power=25.84 V. Fire Diagram index= 0	
Power On- 2018 . 8 . 15 . 20 : 16	Power Off: 2018 . 10 . 11 . 19 : 52 .
Power On- 2018 . 6 . 29 . 16 : 58	Power Off: 2018 . 6 . 29 . 19 : 17 .
Power On- 2018 . 6 . 29 . 16 : 24	Power Off: 2018 . 6 . 29 . 16 : 57 .
Power On- 2018 . 6 . 29 . 1 : 35	Power Off: 2018 . 6 . 29 . 16 : 24 .
Power On- 2018 . 6 . 29 . 1 : 33	Power Off: 2018 . 6 . 29 . 1 : 34 .



## 8.0 Accessories

### 8.1 Swivel Arm Assembly (P/N: DA-001)

Swivel Arm assembly is fabricated from 316 stainless steel and shipped fully assembled. It consists of three sections: mounting base, center piece, and detector holding piece. It has a ratchet design allowing detector rotation in vertical and horizontal planes.

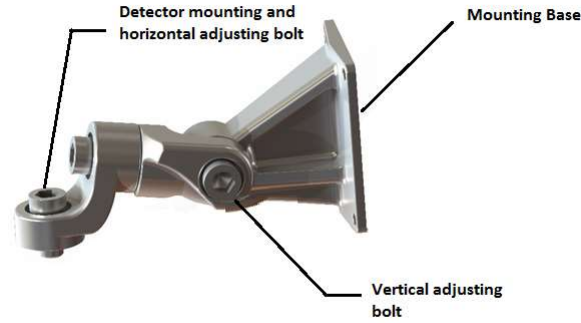

316 Stainless Steel Swivel Arm

**Fig. 2 – Swivel Mounting Arm**

To install the Swivel Arm Assembly:

5. Unpack and inspect the Swivel Arm assembly.
6. Place the mounting base on a rigid and flat surface and secure it with (4) 7mm or 1/4" bolts of proper length (bolts not supplied).
7. Place the detector under the Swivel Arm assembly and secure it to the detector holding piece of the Swivels Arm assembly with an M16 bolt supplied with the Swivel Arm assembly, tighten the bolt.

**8.2** Detector can now be adjusted vertically and horizontally by loosening the vertical and horizontal M16 bolts on the Swivel Arm assembly and aiming the detector to the hazard area.

## 9.0 Product Support

### 9.1 Technical Support and Customer Support

For Technical and Customer Support and questions concerning the detectors or applications, please contact:

Detectors Inc. Türkiye  
Bahcesehir 1. Kısım Mah. Dalgıckusu Cad.  
Defne 05 Ada 02 Villa  
Basaksehir / Istanbul / Turkey



Tel : (0212) 944 57 00  
Email : info@detectorsincturkiye.com  
Web : www.detectorsincturkiye.com

## 10.0 Warranty

Detectors Incorporated warrants the products manufactured and supplied by Detectors Incorporated against defects in materials and workmanship under normal use and service for a period of Five (5) years from the date of shipment. Detectors Incorporated at its sole discretion will repair or replace at no charge any products found to be defective during the warranty period. The defective product must be shipped transportation paid to Detectors Incorporated or Distributor/Representative where the products was purchased. This express limited warranty is extended by Detectors Incorporated to the original purchaser only and is not assignable or transferable to any other party.

This warranty does not cover the following:

1. Damage incurred in transit.
2. Defects or damage from misuse, accident, "Act of God", or neglect.
3. Defects or damage from improper installation, lack of maintenance, improper testing and operation.
4. Defects or damage caused by alterations, unauthorized dis-assemblies, repairs or modifications.
5. Damages caused by applying high voltage, electrical power surge or faulty power supplies.
6. Transportation charges to and from repair facility.
7. Illegal or unauthorized alterations of the firmware/software in the product.

This is the complete warranty for the products manufactured by Detectors Incorporated. Except for the warranty expressed above, Detectors Incorporated disclaims all other warranties express or implied with regards to its products sold. Detectors Incorporated sole liability under this warranty is limited only to repair or replacement of the products and shall not include any liability for consequential or other damages arising from the use of the product.

Detectors Inc. Türkiye  
Bahcesehir 1. Kısım Mah. Dalgıckusu Cad.  
Defne 05 Ada 02 Villa  
Basakşehir / İstanbul / Turkey



Tel : (0212) 944 57 00  
Email : info@detectorsincturkiye.com  
Web : www.detectorsincturkiye.com

## APPENDIX "A"

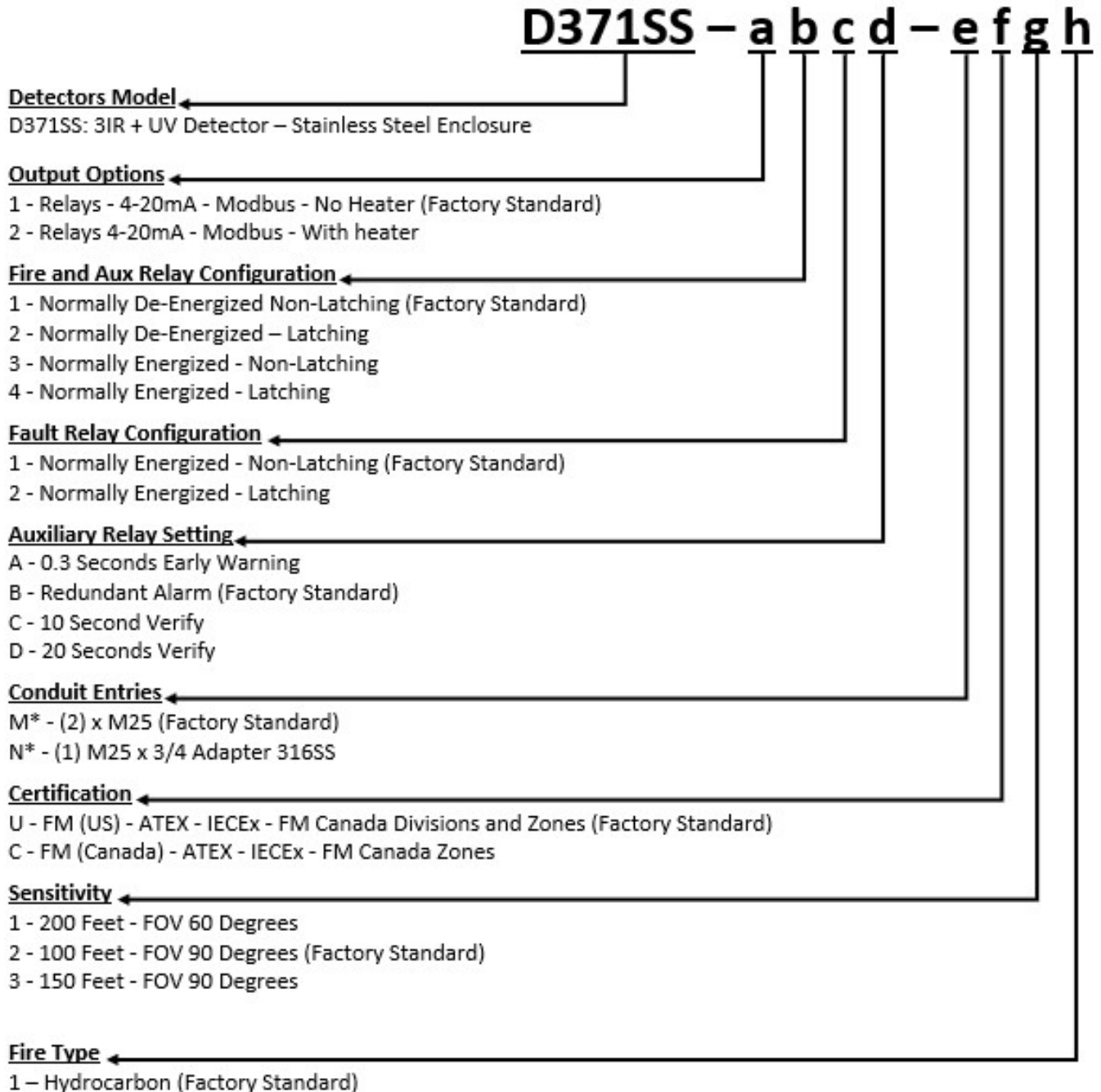

Figure 2

- When conduit entries selection is "M" certification is "C". When conduit entries selection is "N" Certification is "U or C".

**Configured Part Example: D371SS – 1 1 1 B – N U 2 1**

## APPENDIX "B"

### Approvals & Certifications - Detector D371SS



Certification No: **FMI7US0336X**  
Class I, Div. 1, Groups A, B, C and D; Ta = -40°C to +110°C  
Class II/ II, Groups E, F and G; T4, -40°C to +85°C  
T4 = -40°C to +85°C, T5 = -40°C to +75°C, T6 = -40°C to +60°C

Class I, Zone 1 AEx db eb IIC T4 Gb, Ta = -40°C to +110°C  
AEx tb IIIC 135°C Db T4, Ta = Ta = -40°C to +110°C  
T4 = -40°C to +85°C, T5 = -40°C to +75°C, T6 = -40°C to +60°C  
Type 4X and IP66/IP67

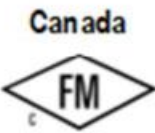

Certification No: **FMI7CA0120X**  
Class I, Div. 1, Groups A, B, C and D; T4, Ta = -40°C to +110°C  
Class II/ II, Groups E, F and G; T4, Ta = -40°C to +110°C  
T4 = -40°C to +85°C, T5 = -40°C to +75°C, T6 = -40°C to +60°C

Class I, Zone 1 Ex db eb IIC T4 Gb, Ta = -40°C to +110°C  
Ex tb IIIC 135°C Db T4, Ta = Ta = -40°C to +110°C  
T4 = -40°C to +85°C, T5 = -40°C to +75°C, T6 = -40°C to +60°C  
Type 4X and IP66/IP67



Certificate Number: **FMI7ATEX0101X**  
(II 2 G) Ex db eb IIC T4 Gb, Ta = -40°C to +110°C  
(II 2 D) Ex tb IIIC T135°C Db, Ta = -40°C to +110°C  
T4 = -40°C to +85°C, T5 = -40°C to +75°C, T6 = -40°C to +60°C  
IP66/ IP67



Certificate Number: **IECEX FMG 17.0034X**  
Zone 21, AEX tb IIIC 135°C Db T4, Ta = Ta = -40°C to +110°C  
T4 = -40°C to +85°C, T5 = -40°C to +75°C, T6 = -40°C to +60°C  
Ex db eb IIC T4 Gb, Ta = -40°C to +110°C  
Ex tb IIIC T135°C Db, Ta = -40°C to +110°C  
T4 = -40°C to +85°C, T5 = -40°C to +75°C, T6 = -40°C to +60°C  
IP66/ IP67

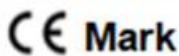

Meets or Exceeds MIL-STD 810C. In Compliance with  
FM 3260-2003

